

# AV Automatic Valve

A ROSS CONTROLS Company

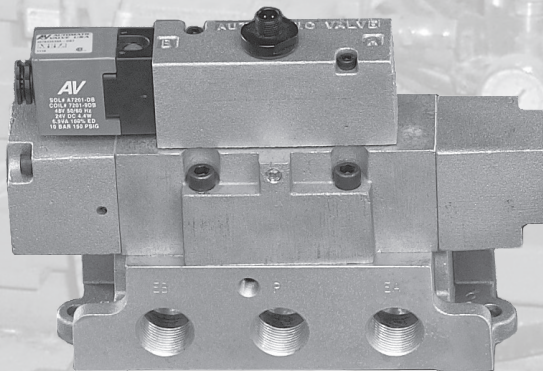
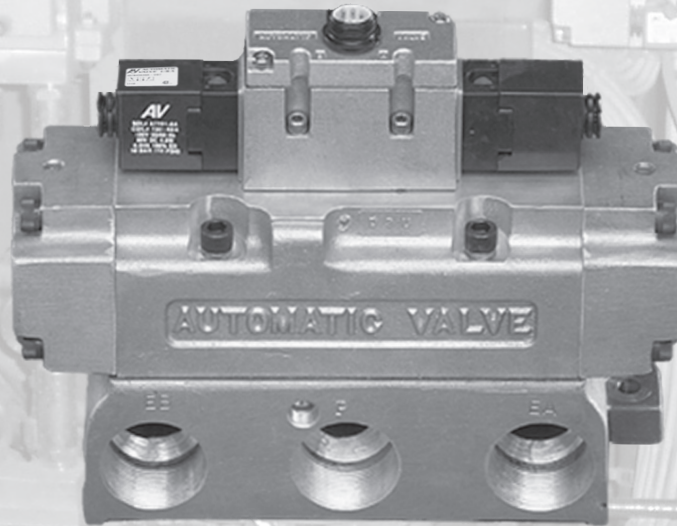
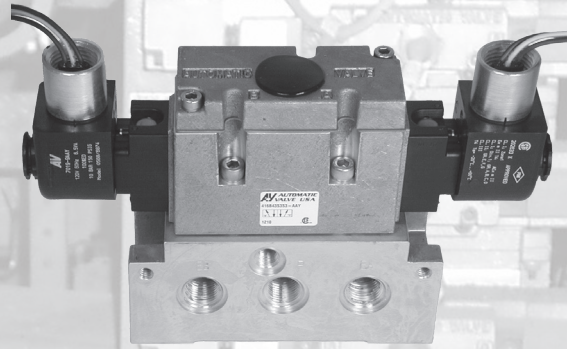

## SAE Spool Valves

	Page
Design Features	F2
Configuration: Valve to Base	F2
Specifications	F3
Model Number	F3
Standard Solenoid	F4-F9
Air Pilot	F10-F15
Manual	F16-F18
Sub-Bases & Manifolds	F19-F22
Options	F23
Accessories	F23-F24
Electrical Information	F25
Service Information	F26-F29

5/2



5/3

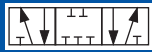

# SAE Spool Valves Design Features

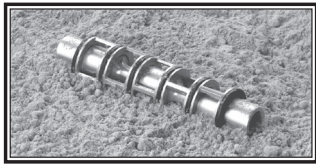
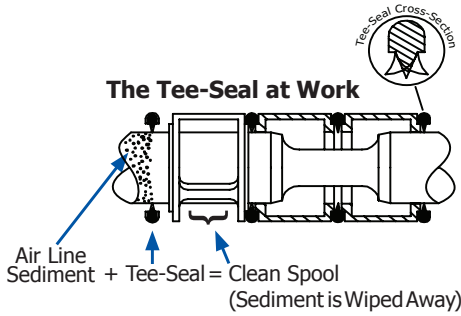

## Valves

- Conforms to SAE J2051 specifications for series 125, 250 and 1000.
- Flow Range of 2 to 20 Cv.
- Complete range of bases and operators available.
- Do you have specific application needs? Consult the factory. We will build it for you.

## Tapered Tee-Seal..... Eats Dirt

- Bidirectional tapered Tee-Seal eliminates sticking problems.
  - Flexes to clean spool
  - Mechanically Locked
  - No Spiral Twist
  - No Extrusion
  - Air Line Sediment is Wiped Away.
- Tested tough and proven reliable according to SAE specifications: Rust and water injected every 864,000 cycles for 20 million cycles.

## Solenoid ... Guaranteed Against Burnout

- Three-way pilot uses full air line pressure to shift the valve.
- Pilot is internally supplied when the pressure at port one is 35 to 150 PSIG (240 to 1030 kPa).
- Coil is hermetically sealed as an integral watertight molded unit.
- Intrinsically-safe and explosion-proof versions available.
- Push Non-Locking Override is standard.

## Products Certified To:

- CSA - (C22.2 and UL STD 429)
- Factory Mutual - Explosion Proof Environments
- ATEX - Explosion Proof Environments
- CE - EMF and Low Voltage Directives

## F Configuration: Valve to Base

Description	Configuration	Model Number Prefix	Available Series
Valve Only		= <b>407</b>	A04 (125) A06 (250) A20 (1000)
Valve + Sub-Base		= <b>409</b>	A04 (125) A06 (250) A20 (1000)
Valve + Manifold (Bottom Cylinder Ports)		= <b>413</b>	A04 (125) A06 (250)
Valve + Manifold (Bottom/Side Cylinder Ports)		= <b>416</b>	A04 (125) A06 (250)



# SAE Spool Valves Specs & Model Numbers

5/2



5/3



SAE Spool Valves

## Specifications

Valve Operation		Valve Operation	
<p><b>A04</b>      <b>A06</b>      <b>A20</b></p>		<p><b>5/3 BLOCK</b>  <b>Maintained Energized 12:</b>            Pressure from Port 1 to Port 2            Exhaust from Port 4 to Port 5  <b>De-Energized:</b> All ports Blocked  <b>Maintained Energized 14:</b>            Pressure from Port 1 to Port 4            Exhaust from Port 2 to Port 3</p>	
<p><b>5/2 SINGLE</b>  <b>De-Energized:</b>            Pressure from Port 1 to Port 2            Exhaust from Port 4 to Port 5  <b>Energized:</b>            Pressure from Port 1 to Port 4            Exhaust from Port 2 to Port 3</p>		<p><b>5/3 EXHAUST</b>  <b>Maintained Energized 12:</b>            Pressure from Port 1 to Port 2            Exhaust from Port 4 to Port 5  <b>De-Energized:</b>            Port 2 open to Port 3, Port 4 open to Port 5            Port 1 Blocked  <b>Maintained Energized 14:</b>            Pressure from Port 1 to Port 4            Exhaust from Port 2 to Port 3</p>	
<p><b>5/2 DOUBLE</b>  <b>Momentarily Energized 12:</b>            Pressure from Port 1 to Port 2            Exhaust from Port 4 to Port 5  <b>Momentarily Energized 14:</b>            Pressure from Port 1 to Port 4            Exhaust from Port 2 to Port 3</p>		<p><b>5/3 PRESSURE</b>  <b>Maintained Energized 12:</b>            Pressure from Port 1 to Port 2            Exhaust from Port 4 to Port 5  <b>De-Energized:</b>            Port 1 open to Ports 2 &amp; 4; Ports 3 &amp; 5 Blocked  <b>Maintained Energized 14:</b>            Pressure from Port 1 to Port 4            Exhaust from Port 2 to Port 3</p>	
<b>Operating Temperatures</b> 	<b>Solenoid Pilot Operated</b>	<b>Treated Buna-N Seals (Treated NBR, Standard)</b>	<b>Fluoroelastomer Seals (FPM (FKM), Option A)</b>
	Standard	-18°C to +50°C (0°F to +123°F)	-18°C to +50°C (0°F to +123°F)
<b>Operating Pressures</b> 	<b>Solenoid Pilot Operated</b>	<b>Inlet Port</b>	<b>External Pilot Port</b>
	Standard 2 Position	240 - 1030 kPa (35 - 150 PSIG)	-
	Standard 3 Position	345 - 1030 kPa (50 - 150PSIG)	-
External Pilot (Option B)	Vacuum - 240 kPa (Vacuum - 35 PSIG)	240 - 1030 kPa (35 - 150 PSIG)	
<b>Filtration &amp; Lubrication</b> 	<b>Media - Air Or Inert Gas</b> Air Line Lubrication of Automatic Valve products is not required, but is recommended to maximize service life. Oils should be compatible with seal material, have an ISO 32 viscosity, and have an aniline range between 82°C (180°F) and 99°C (210°F). Filter to 50 microns or better. For temperatures below 40°F, air must be dry to prevent formation of ice. Refer to the Maintenance section of this catalog for recommended lubricants.		

F

## Model Numbers

Series	Body Type		Function	Series		Operator 1	Center Operator	Operator 2	Voltage <sup>1</sup>	Options*
				#	Port Size					
<b>A04 (125)</b>	407	Valve Only	B 4 Way 2 Position	43	-	S3 Weather-Proof Solenoid 1A Air Pilot 3B Hand Lever (A04 & A06)	9D 3 Position Spring Center (Solenoid & Air Pilot)	S3 Weather-Proof Solenoid 1A Air Pilot 1C 2 Position Air Return (A06) 7A 2 Position Detent 7B 3 Position Detent 9A 2 Position Spring Return 9B 3 Position Spring Center (For Manual Operators)	-AA 110/50, 120/60 -AB 220/50, 240/60, 125VDC -DA 22/50, 24/60, 12VDC -DB 24VDC	A Fluoroelastomer Seals (A04 & A06)
	409	Valve with Sub-Base	C 4 Way 3 Position Block	42	1/4					B External Pilot Connection
	413	Valve with Manifold (Bottom Cylinder Ports)	D 4 Way 3 Position Exhaust	43	3/8					D Dustproof
	416	Valve with Manifold (Bottom-Side Cylinder Ports)	E 4 Way 3 Position Pressure	67	-					Y Explosion-Proof Coil (CSA,FM)
<b>A06 (250)</b>	407	Valve Only		65	1/2				0 GM - 5 Pin Micro	
	409	Valve with Sub-Base		67	3/4				1 Ford - 5 Pin Micro	
				60	1				2 Chrysler - 5 Pin Micro AC/DC	
	413	Valve with Manifold (Bottom Cylinder Ports)		65	1/2				3 GM - 5 Pin Mini	
	416	Valve with Manifold (Bottom-Side Cylinder Ports)		67	3/4				4 Ford - 5 Pin Mini	
<b>A20 (1000)</b>	407	Valve Only		12	-				5 Chrysler - 5 Pin Mini	
	409	Valve with Sub-Base		12	1 1/4				6 GM - 4 Pin Micro DC	
				15	1 1/2				7 Ford - 4 Pin Micro DC	

\* Not all Options are available for all models. Refer to "Options" at the end of this Section for additional information.  
<sup>1</sup> Consult the Factory for additional voltages.

5/2



5/3

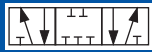

# SAE Spool Valves Standard Solenoid



## A04 (125 Series) - Single Weather-Proof (W-P)

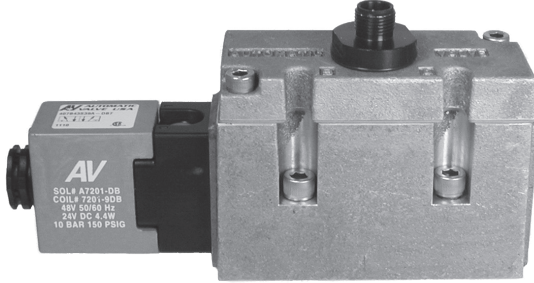

407B43S39A-DB7

## Explosion-Proof

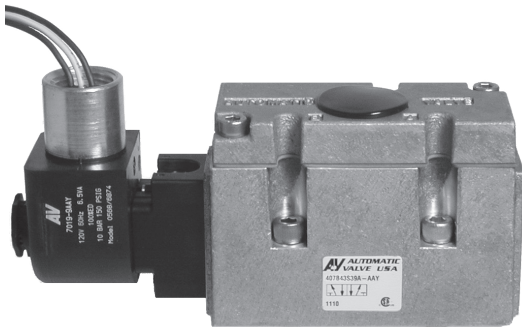

407B43S39A-AA7

## A04 (125 Series) - Double Weather-Proof (W-P)

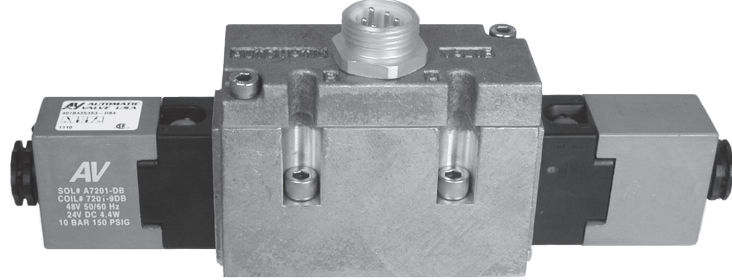

407B43S3S3-DB4

## Explosion-Proof

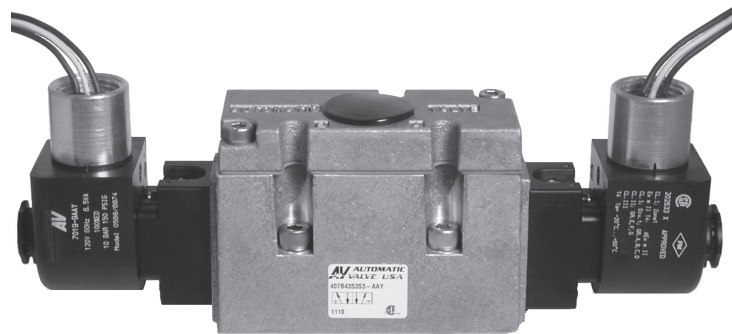

407B43S3S3-AA7

## Model Numbers

Body Type	Port Loc'n	Port Size	Flow l/min (Cv)	Operator <sup>1</sup>	5/2		5/3			Materials	Weight Kg (lb)
					Single	Double	Block	Exhaust	Pressure		
Valve Only	-	-	5/3 Flow: 1841(1.9)	W-P	407B43S39A-**	407B43S3S3-**	407C43S39DS3-**	407D43S39DS3-**	407E43S39DS3-**	Body=Aluminum Seal =NBR	2,0 (4.5)
				E-P	407B43S39A-**Y	407B43S3S3-**Y	407C43S39DS3-**Y	407D43S39DS3-**Y	407E43S39DS3-**Y		
Valve + Sub-Base	1/4	-	5/3 Flow: 1841(1.9)	W-P	409B42S39A-**	409B42S3S3-**	409C42S39DS3-**	409D42S39DS3-**	409E42S39DS3-**	Body=Aluminum Seal =NBR	2,4 (5.4)
				E-P	409B42S39A-**Y	409B42S3S3-**Y	409C42S39DS3-**Y	409D42S39DS3-**Y	409E42S39DS3-**Y		
Valve + Manifold (Bottom/Cyl Ports)	3/8	-	5/3 Flow: 2360(2.4)	W-P	413B43S39A-**	413B43S3S3-**	413C43S39DS3-**	413D43S39DS3-**	413E43S39DS3-**	Body=Aluminum Seal =NBR	2,5 (5.5)
				E-P	413B43S39A-**Y	413B43S3S3-**Y	413C43S39DS3-**Y	413D43S39DS3-**Y	413E43S39DS3-**Y		
Valve + Manifold (Bottom/Side Cyl Ports)	3/8	-	5/2 Flow: 2360(2.4)	W-P	416B43S39A-**	416B43S3S3-**	416C43S39DS3-**	416D43S39DS3-**	416E43S39DS3-**	Body=Aluminum Seal =NBR	2,7 (5.9)
				E-P	416B43S39A-**Y	416B43S3S3-**Y	416C43S39DS3-**Y	416D43S39DS3-**Y	416E43S39DS3-**Y		

\*\* = Coil Voltage Code. Coils also sold separately. Refer to "Electrical Information" at the end of this Section for additional information.

<sup>1</sup> W-P = Weather-Proof; E-P = Explosion-Proof



# SAE Spool Valves Standard Solenoids

5/2



5/3

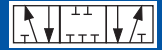

SAE Spool Valves

## Dimensional Information

### A04 (125 Series) - Single

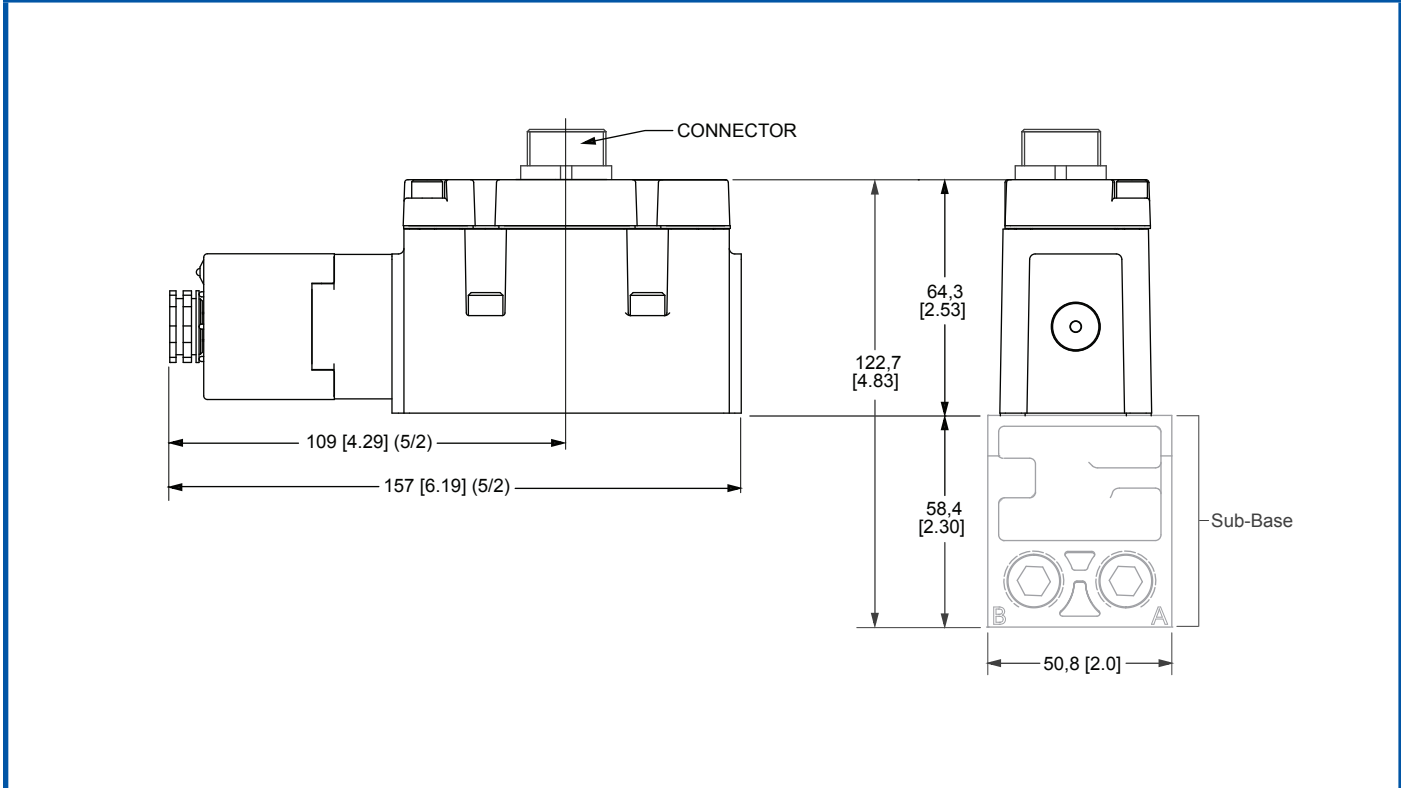

### A04 (125 Series) - Double

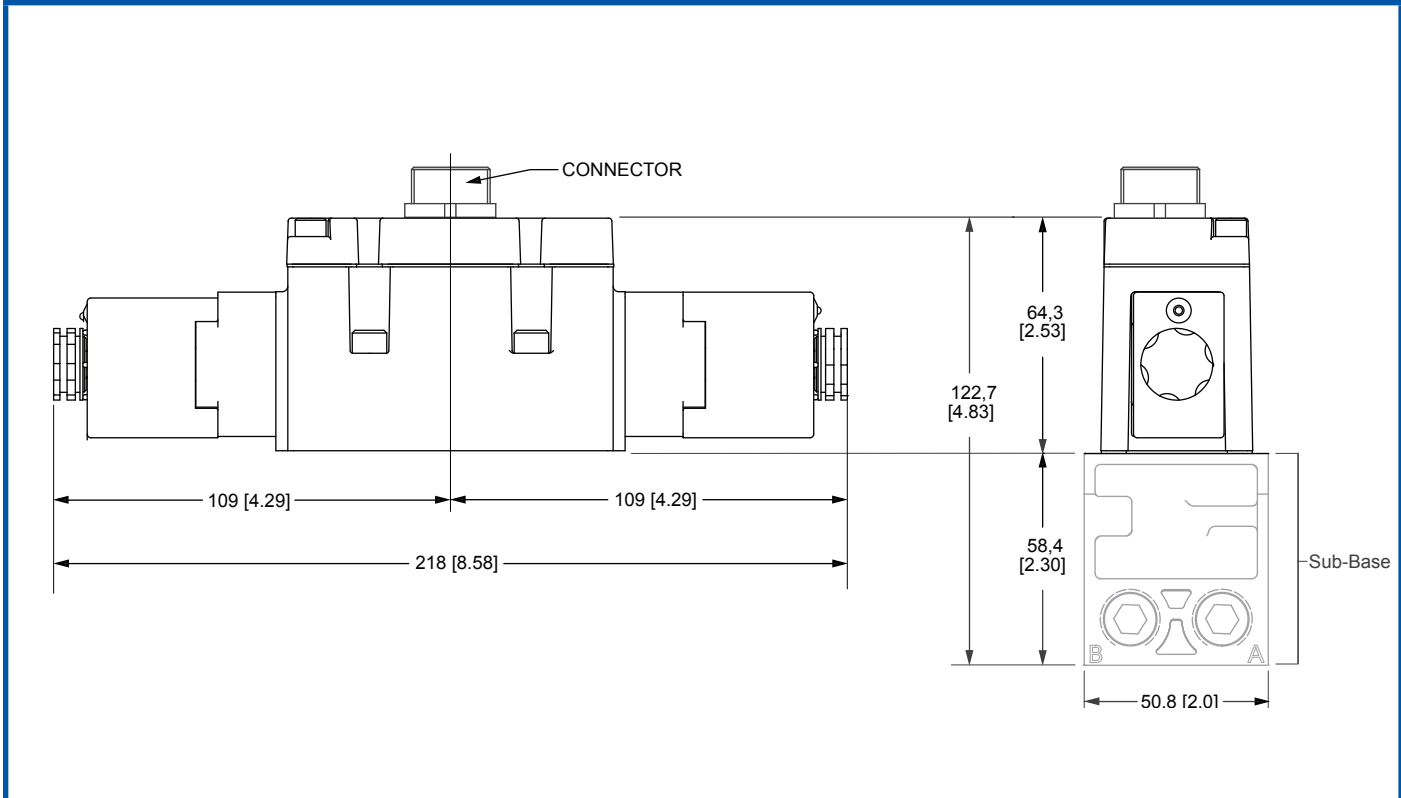

Units of Measure: Top - mm, Bottom - inches

F

5/2



5/3



# SAE Spool Valves Standard Solenoid



## A06 (250 Series) - Single Weather-Proof (W-P)

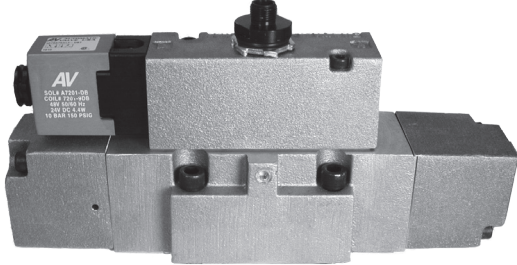

407B67S31C-DB7

## Explosion-Proof

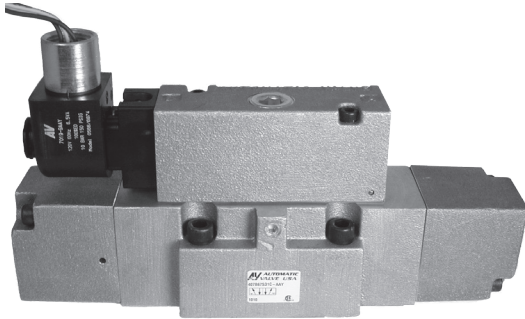

407B67S39A-AA7

## A06 (250 Series) - Double Weather-Proof (W-P)

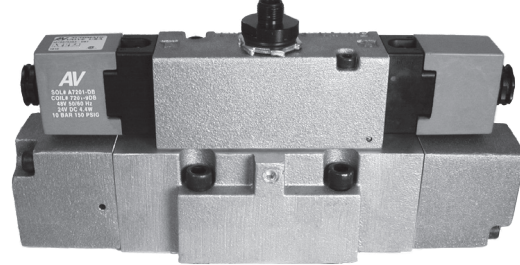

407B67S3S3-DB7

## Explosion-Proof

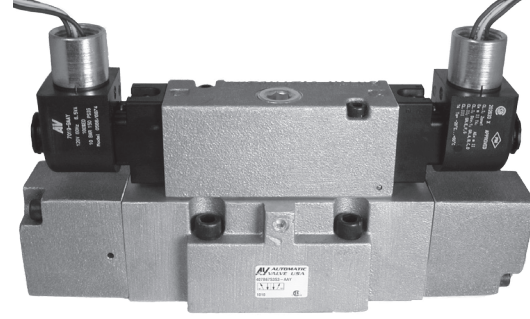

407B67S3S3-AA7

## Model Numbers

Body Type	Port Loc'n	Port Size	Flow l/min (Cv)	Operator <sup>1</sup>	5/2		5/3			Materials	Weight kg (lb)
					Single	Double	Block	Exhaust	Pressure		
Valve Only	-	-	5/2 Flow: 6599 (6.7)	W-P	407B67S39A-**	407B67S3S3-**	407C67S39DS3-**	407D67S39DS3-**	407E67S39DS3-**	Body=Aluminum Seal+NBR	3,7 (8.3)
		E-P		407B67S39A-**Y	407B67S3S3-**Y	407C67S39DS3-**Y	407D67S39DS3-**Y	407E67S39DS3-**Y			
Valve + Sub-Base	1/2	3/4	5/3 Flow: 8460 (8.6)	W-P	409B65S39A-**	409B65S3S3-**	409C65S39DS3-**	409D65S39DS3-**	409E65S39DS3-**		5,0 (11.0)
				E-P	409B65S39A-**Y	409B65S3S3-**Y	409C65S39DS3-**Y	409D65S39DS3-**Y	409E65S39DS3-**Y		
	W-P	409B67S39A-**		409B67S3S3-**	409C67S39DS3-**	409D67S39DS3-**	409E67S39DS3-**				
	E-P	409B67S39A-**Y		409B67S3S3-**Y	409C67S39DS3-**Y	409D67S39DS3-**Y	409E67S39DS3-**Y				
Valve + Manifold (Bottom Cyl Ports)	1/2	3/4		W-P	409B60S39A-**	409B60S3S3-**	409C60S39DS3-**	409D60S39DS3-**	409E60S39DS3-**		5,0 (11.0)
				E-P	409B60S39A-**Y	409B60S3S3-**Y	409C60S39DS3-**Y	409D60S39DS3-**Y	409E60S39DS3-**Y		
	W-P	413B65S39A-**		413B65S3S3-**	413C65S39DS3-**	413D65S39DS3-**	413E65S39DS3-**				
	E-P	413B65S39A-**Y		413B65S3S3-**Y	413C65S39DS3-**Y	413D65S39DS3-**Y	413E65S39DS3-**Y				
Valve + Manifold (Bottom/Side Cyl Ports)	1/2	3/4		W-P	413B67S39A-**	413B67S3S3-**	413C67S39DS3-**	413D67S39DS3-**	413E67S39DS3-**		4,5 (10.1)
				E-P	413B67S39A-**Y	413B67S3S3-**Y	413C67S39DS3-**Y	413D67S39DS3-**Y	413E67S39DS3-**Y		
	W-P	416B65S39A-**		416B65S3S3-**	416C65S39DS3-**	416D65S39DS3-**	416E65S39DS3-**				
	E-P	416B65S39A-**Y		416B65S3S3-**Y	416C65S39DS3-**Y	416D65S39DS3-**Y	416E65S39DS3-**Y				
	3/4			W-P	416B67S39A-**	416B67S3S3-**	416C67S39DS3-**	416D67S39DS3-**	416E67S39DS3-**		4,5 (10.1)
				E-P	416B67S39A-**Y	416B67S3S3-**Y	416C67S39DS3-**Y	416D67S39DS3-**Y	416E67S39DS3-**Y		

\*\* = Coil Voltage Code. Coils also sold separately. Refer to "Electrical Information" at the end of this Section for additional information.

<sup>1</sup> W-P = Weather-Proof; E-P = Explosion-Proof



# SAE Spool Valves Standard Solenoid

5/2



5/3

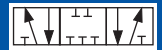

SAE Spool Valves

## Dimensional Information

### A06 (250 Series) - Single

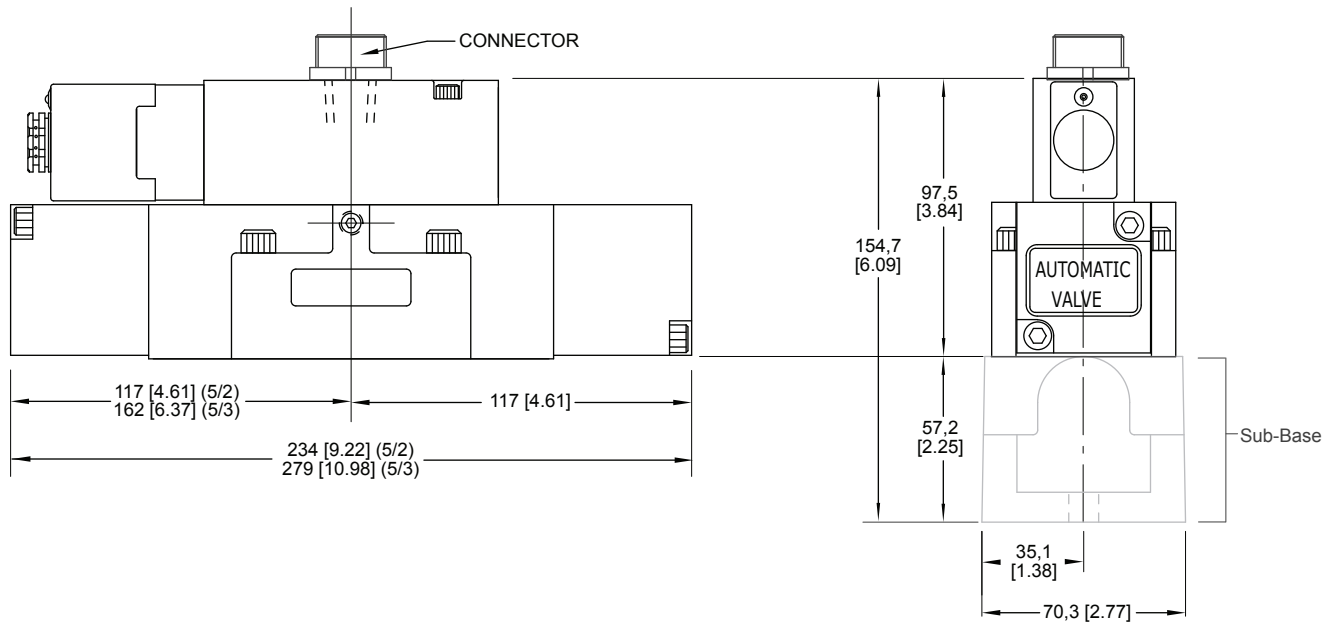

### A06 (250 Series) - Double

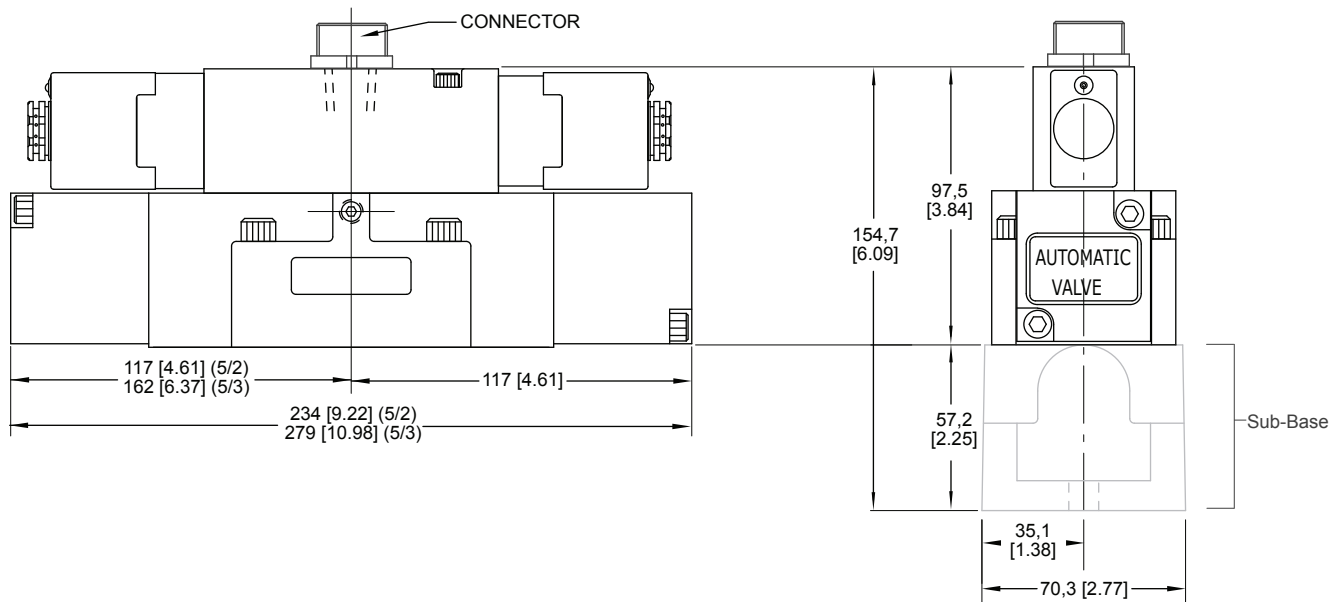

F

Units of Measure: Top - mm, Bottom - inches

5/2



5/3

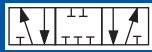

# SAE Spool Valves Standard Solenoid



## A20 (1000 Series) - Single

Weather-Proof (W-P)

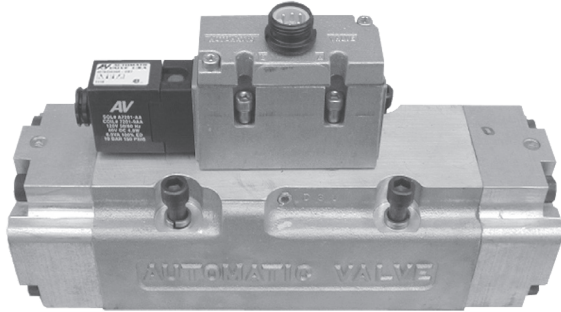

407B12S39A-AA4

Explosion-Proof

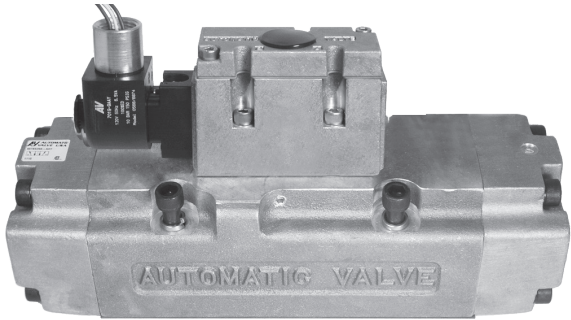

407B12S39A-AAY

## A20 (1000 Series) - Double

Weather-Proof (W-P)

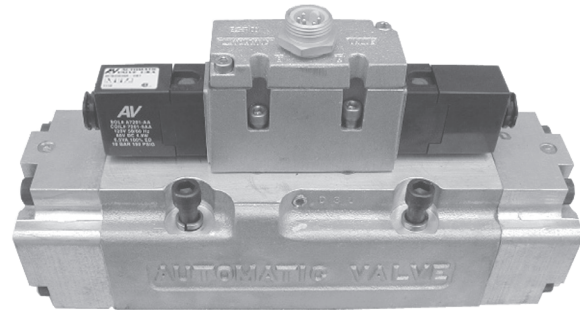

407B12S3S3-AA4

Explosion-Proof

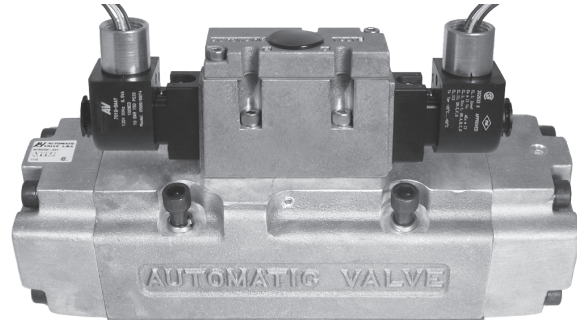

407B12S3S3-AAY

F

## Model Numbers

Body Type	Port Loc'n	Port Size	Flow l/min (Cv)	Operator <sup>1</sup>	5/2		5/3			Materials	Weight Kg (lb)
					Single	Double	Block	Exhaust	Pressure		
Valve Only	-	-	5/2 Flow: 17,425 (17.7)	W-P	407B12S39A-**	407B12S3S3-**	407C12S39DS3-**	407D12S39DS3-**	407E12S39DS3-**	Seal+NBR	8,7 (19,4)
				E-P	407B12S39A-**Y	407B12S3S3-**Y	407C12S39DS3-**Y	407D12S39DS3-**Y	407E12S39DS3-**Y		
Valve + Sub-Base	Base	1	5/3 Flow: 22,340 (22.7)	W-P	409B10S39A-**	409B10S3S3-**	409C10S39DS3-**	409D10S39DS3-**	409E10S39DS3-**	Aluminum	12,0 (26,7)
				E-P	409B10S39A-**Y	409B10S3S3-**Y	409C10S39DS3-**Y	409D10S39DS3-**Y	409E10S39DS3-**Y		
	11/4	W-P		409B12S39A-**	409B12S3S3-**	409C12S39DS3-**	409D12S39DS3-**	409E12S39DS3-**			
		E-P		409B12S39A-**Y	409B12S3S3-**Y	409C12S39DS3-**Y	409D12S39DS3-**Y	409E12S39DS3-**Y			
	11/2	W-P		409B15S39A-**	409B15S3S3-**	409C15S39DS3-**	409D15S39DS3-**	409E15S39DS3-**			
		E-P		409B15S39A-**Y	409B15S3S3-**Y	409C15S39DS3-**Y	409D15S39DS3-**Y	409E15S39DS3-**Y			

\*\* = Coil Voltage Code. Coils also sold separately. Refer to "Electrical Information" at the end of this Section for additional information.

<sup>1</sup> W-P = Weather-Proof; E-P = Explosion-Proof



# SAE Spool Valves Standard Solenoid

5/2



5/3

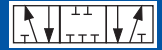

SAE Spool Valves

## Dimensional Information

### A20 (1000 Series) - Single

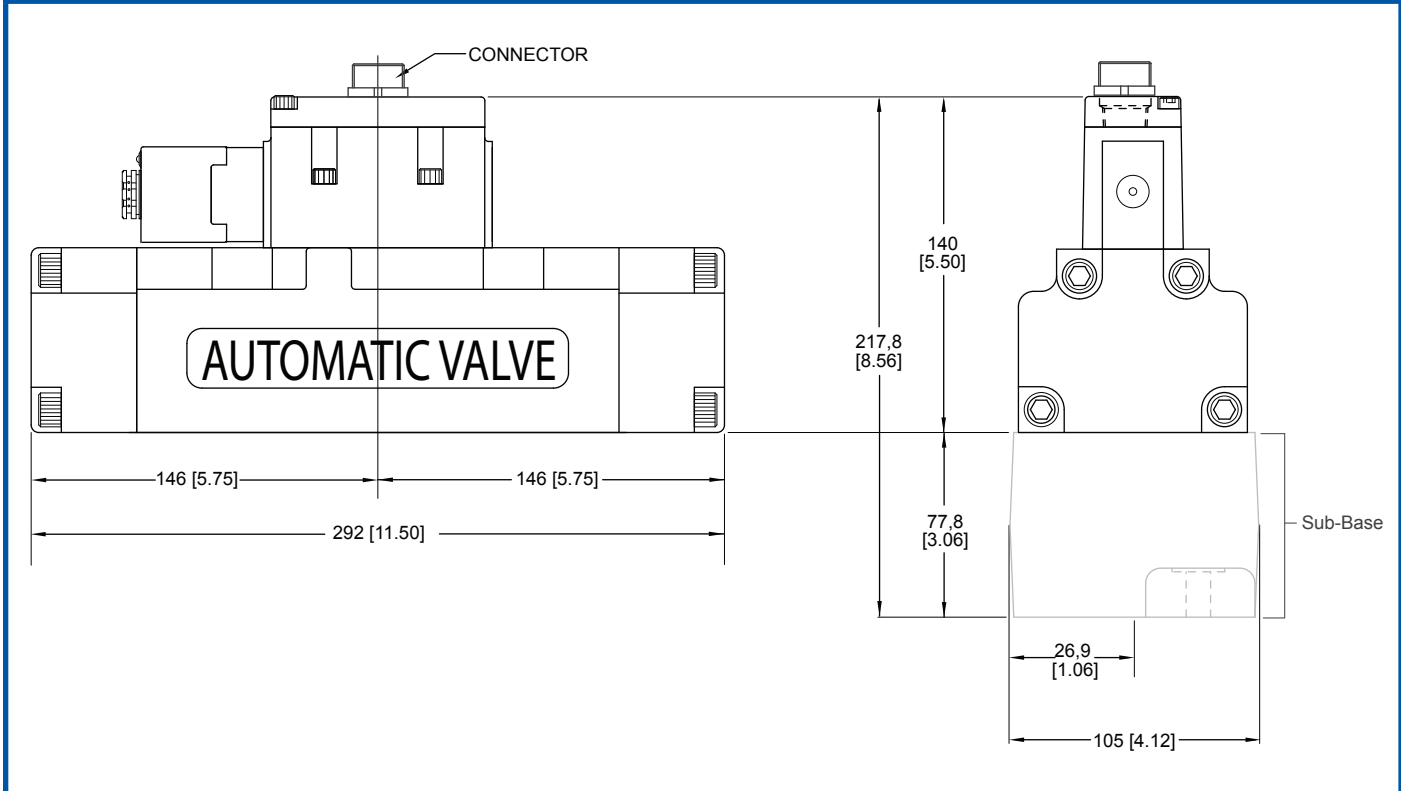

### A20 (1000 Series) - Double

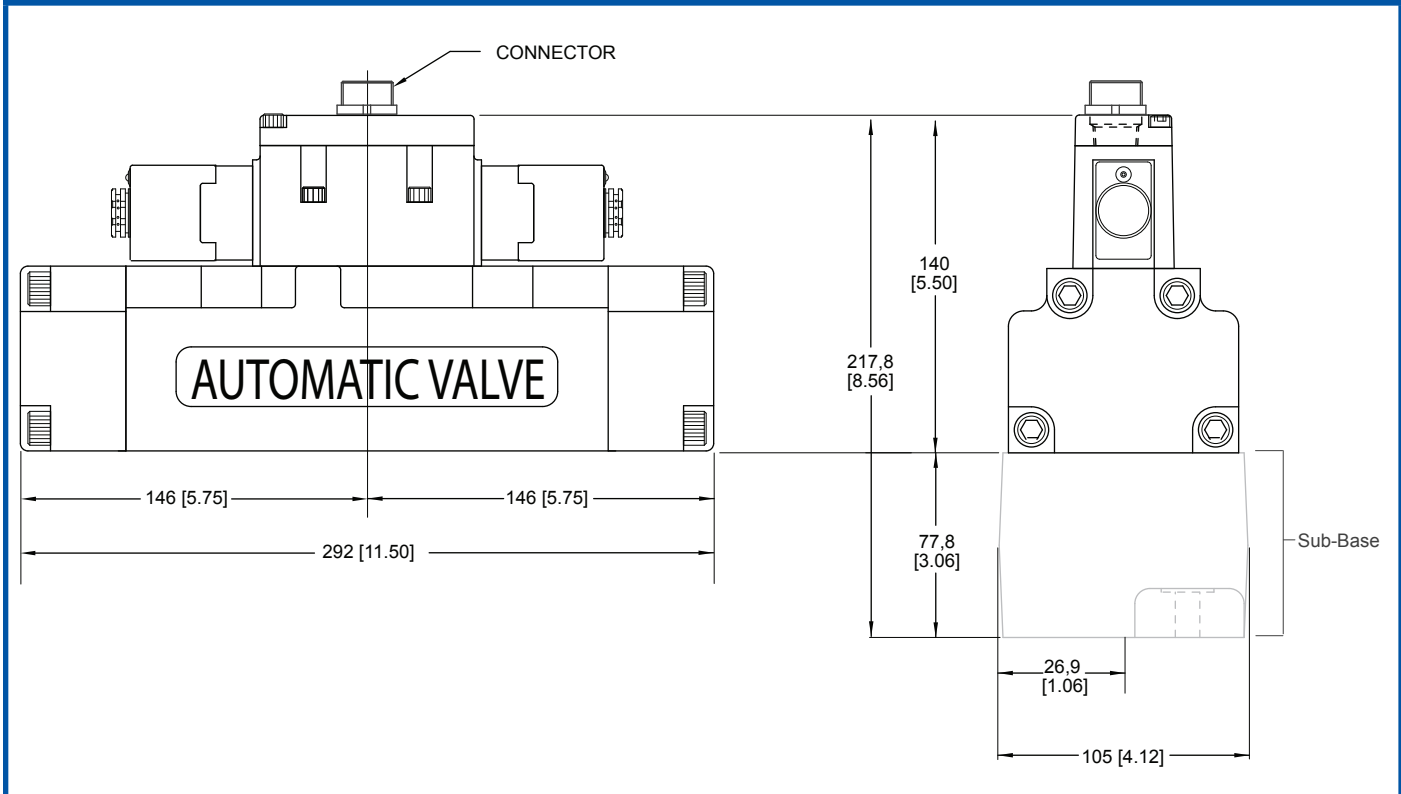

Units of Measure: Top - mm, Bottom - inches

F

5/2



5/3

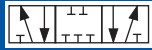

# SAE Spool Valves Air Pilot



**A04 (125 Series) - Single**

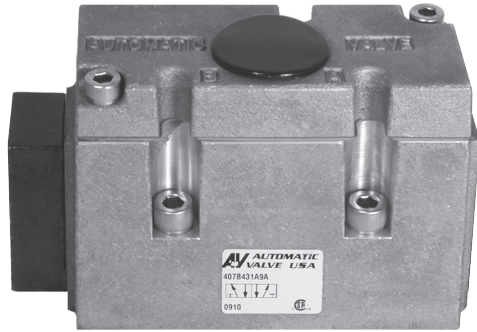

407B431A9A

**A04 (125 Series) - Double**

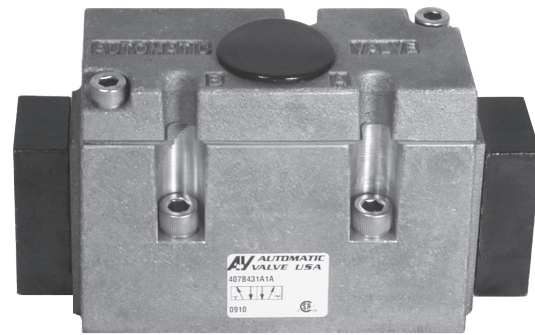

407B431A1A

## Model Numbers

F

Body Type	Port Loc'n	Port Size	Flow l/min (Cv)	5/2		5/3			Materials	Weight (kg (lb))
				Single	Double	Block	Exhaust	Pressure		
Valve Only	-	-	1841 (1.9)	407B431A9A	407B431A1A	407C431A9D1A	407D431A9D1A	407E431A9D1A	Body=Aluminum Seal = NBR	1,0 (2.3)
Valve + Sub-Base	1/4	5/3	Flow: 1841 (1.9)	409B421A9A	409B421A1A	409C421A9D1A	409D421A9D1A	409E421A9D1A		1,4 (3.2)
Valve + Manifold (Bottom Cyl Ports)	3/8	5/2	Flow: 2360 (2.4)	413B431A9A	413B431A1A	413C431A9D1A	413D431A9D1A	413E431A9D1A		1,5 (3.3)
Valve + Manifold (Bottom/Side Cyl Ports)	3/8	5/2	Flow: 2360 (2.4)	416B431A9A	416B431A1A	416C431A9D1A	416D431A9D1A	416E431A9D1A		1,7 (3.7)



# SAE Spool Valves Air Pilot

5/2



5/3

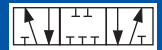

SAE Spool Valves

## Dimensional Information

### A04 (125 Series) - Single

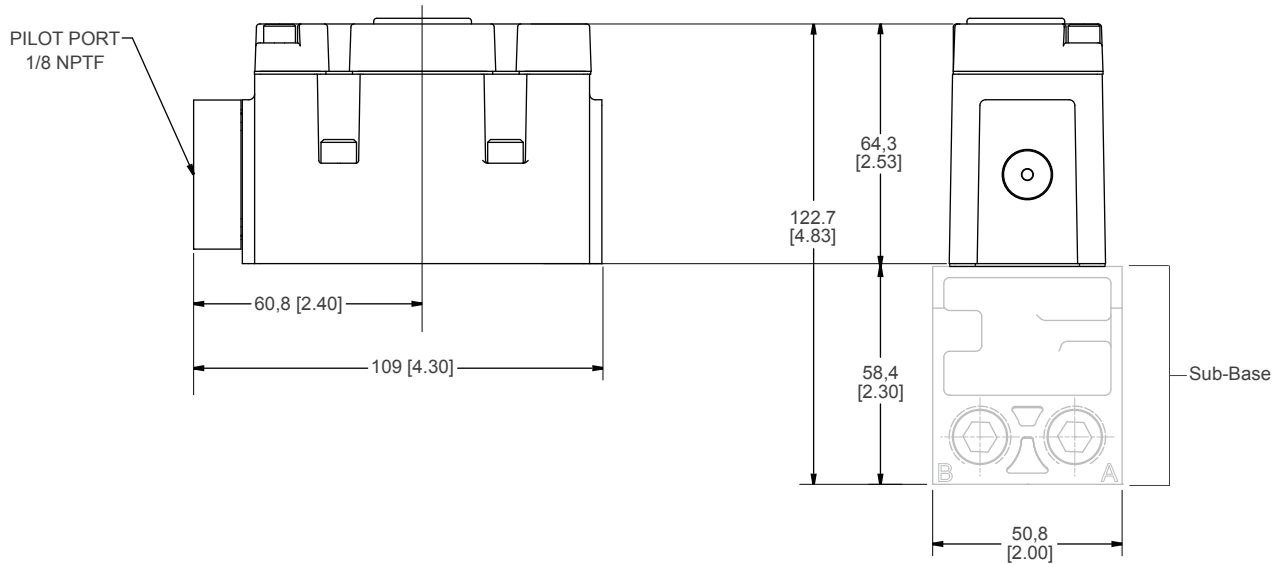

### A04 (125 Series) - Double

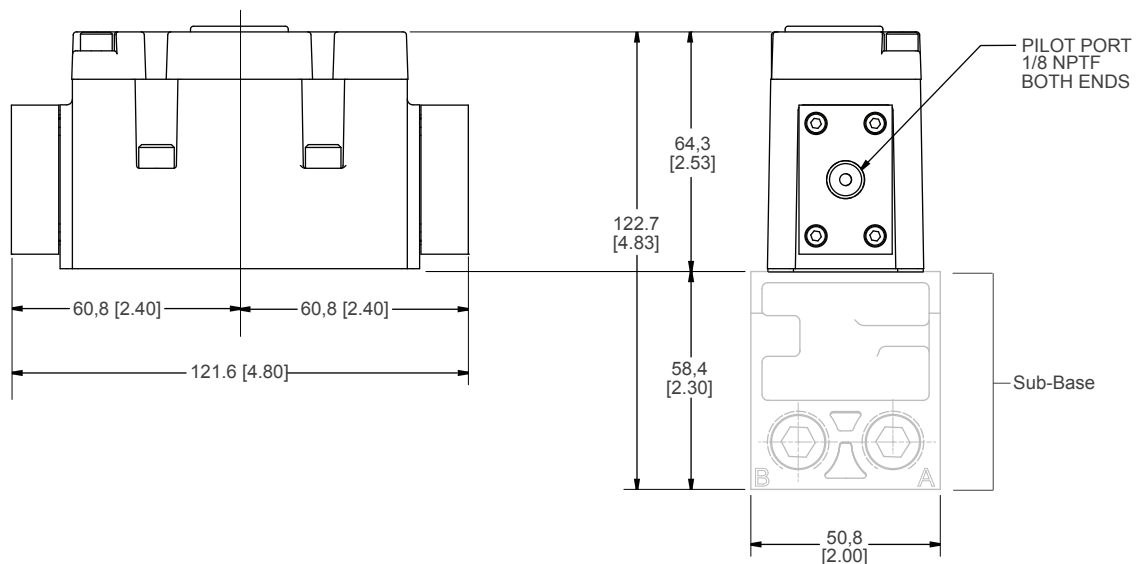

F

Units of Measure: Top - mm, Bottom - inches

5/2



5/3

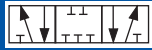

# SAE Spool Valves Air Pilot



## A06 (250 Series) - Single

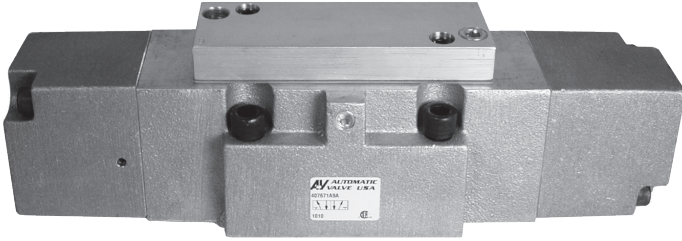

407B671A9A

## A06 (250 Series) - Double

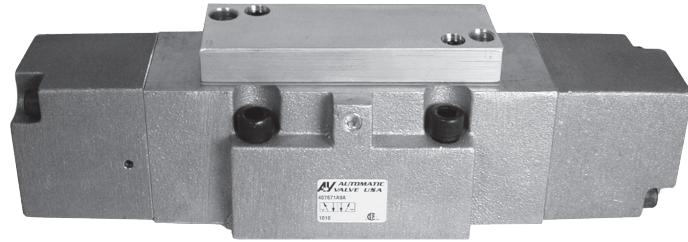

407B671A1A

## Model Numbers

Body Type	Port Loc'n	Port Size	Flow l/min (Cv)	5/2		5/3			Materials	Weight Kg (lb)
				Single	Double	Block	Exhaust	Pressure		
Valve Only	-	-	5/3 Flow: 6599 (6.7)	407B671A9A	407B671A1A	407C671A9D1A	407D671A9D1A	407E671A9D1A	Body=Aluminum Seal = NBR	3,5 (7.8)
Valve + Sub-Base	1/2	1/2		409B651A9A	409B651A1A	409C651A9D1A	409D651A9D1A	409E651A9D1A		4,7 (10.5)
	3/4	3/4		409B671A9A	409B671A1A	409C671A9D1A	409D671A9D1A	409E671A9D1A		
Valve + Manifold (Bottom Cyl Ports)	Base	1	5/2 Flow: 8460 (8.6)	409B601A9A	409B601A1A	409C601A9D1A	409D601A9D1A	409E601A9D1A	4,3 (9.6)	
		1/2		1/2	413B651A9A	413B651A1A	413C651A9D1A	413D651A9D1A		413E651A9D1A
Valve + Manifold (Bottom/Side Cyl Ports)	Base	3/4	5/2 Flow: 8460 (8.6)	413B671A9A	413B671A1A	413C671A9D1A	413D671A9D1A	413E671A9D1A	4,3 (9.6)	
		1/2		1/2	416B651A9A	416B651A1A	416C651A9D1A	416D651A9D1A		416E651A9D1A
Valve + Manifold (Bottom/Side Cyl Ports)	Base	3/4	5/2 Flow: 8460 (8.6)	416B671A9A	416B671A1A	416C671A9D1A	416D671A9D1A	416E671A9D1A	4,3 (9.6)	
		1/2		1/2	416B651A9A	416B651A1A	416C651A9D1A	416D651A9D1A		416E651A9D1A



# SAE Spool Valves Air Pilot

5/2



5/3

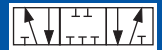

SAE Spool Valves

## Dimensional Information

### A06 (250 Series) - Single

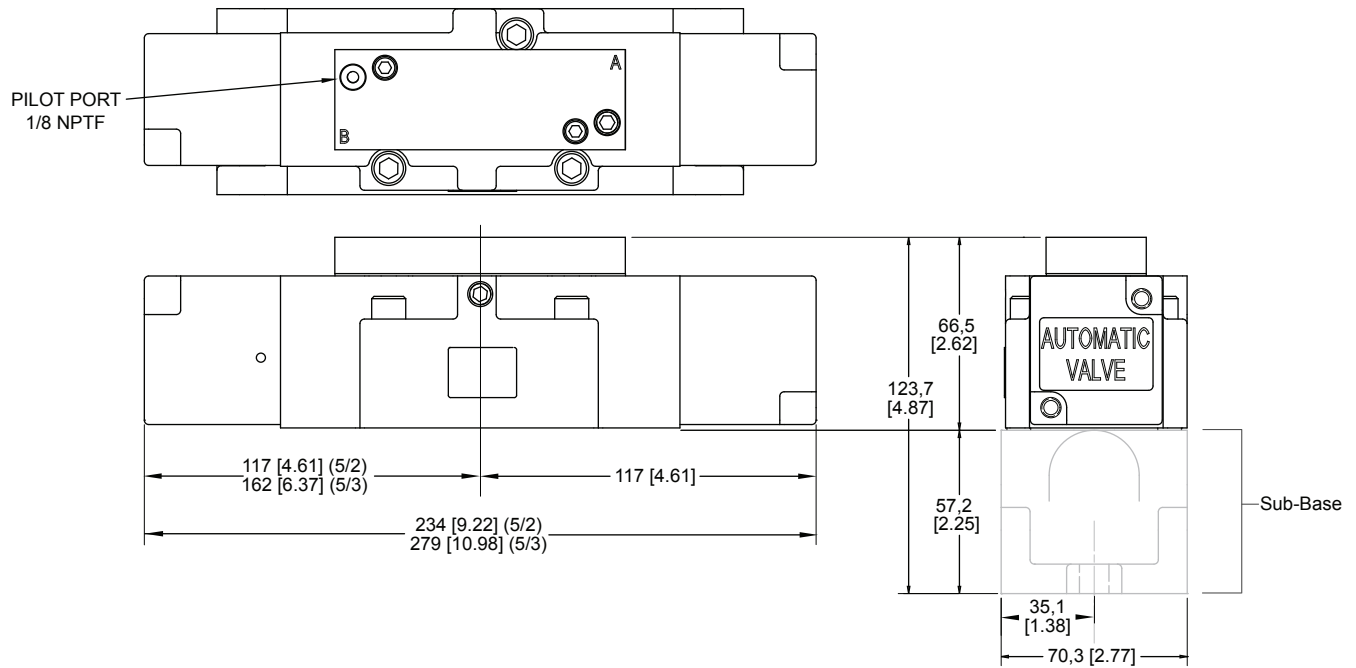

### A06 (250 Series) - Double

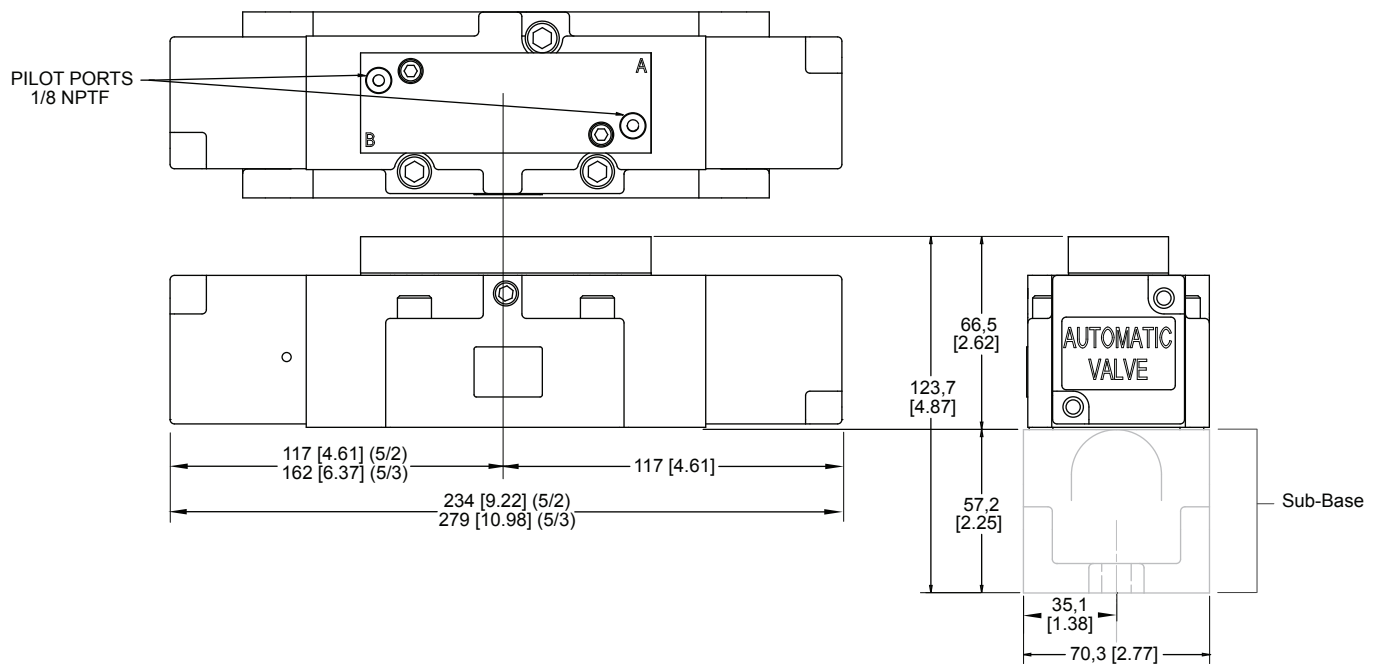

F

Units of Measure: Top - mm, Bottom - inches

5/2



5/3

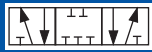

# SAE Spool Valves Air Pilot



**A20 (1000 Series) - Single**

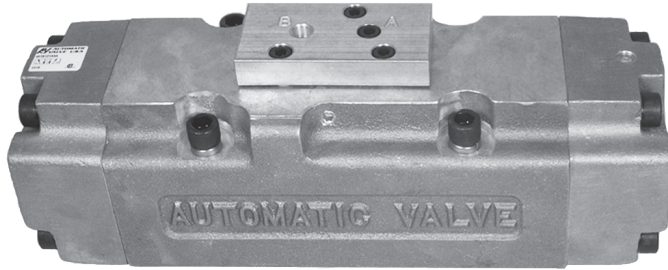

407B121A9A

**A20 (1000 Series) - Double**

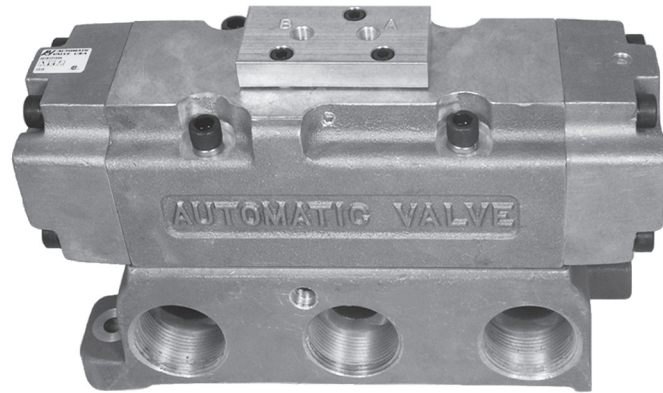

409B151A1A

F

## Model Numbers

Body Type	Port Loc'n	Port Size	Flow l/min (Cv)	5/2		5/3			Materials	Weight Kg (lb)
				Single	Double	Block	Exhaust	Pressure		
Valve Only	-	-	5/2 Flow: 17,425 (17.7)	407B121A9A	407B121A1A	407C121A9D1A	407D121A9D1A	407E121A9D1A	Seal+NBR	8,0 (17.8)
Valve + Sub-Base	Base	1	5/3: 22,340 (22.7)	409B101A9A	409B101A1A	409C101A9D1A	409D101A9D1A	409E101A9D1A	Body=Aluminum	11,3 (25.1)
		1 1/4	409B121A9A	409B121A1A	409C121A9D1A	409D121A9D1A	409E121A9D1A			
		1 1/2	409B151A9A	409B151A1A	409C151A9D1A	409D151A9D1A	409E151A9D1A			



# SAE Spool Valves Air Pilot

5/2



5/3

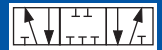

SAE Spool Valves

## Dimensional Information

### A20 (1000 Series) - Single

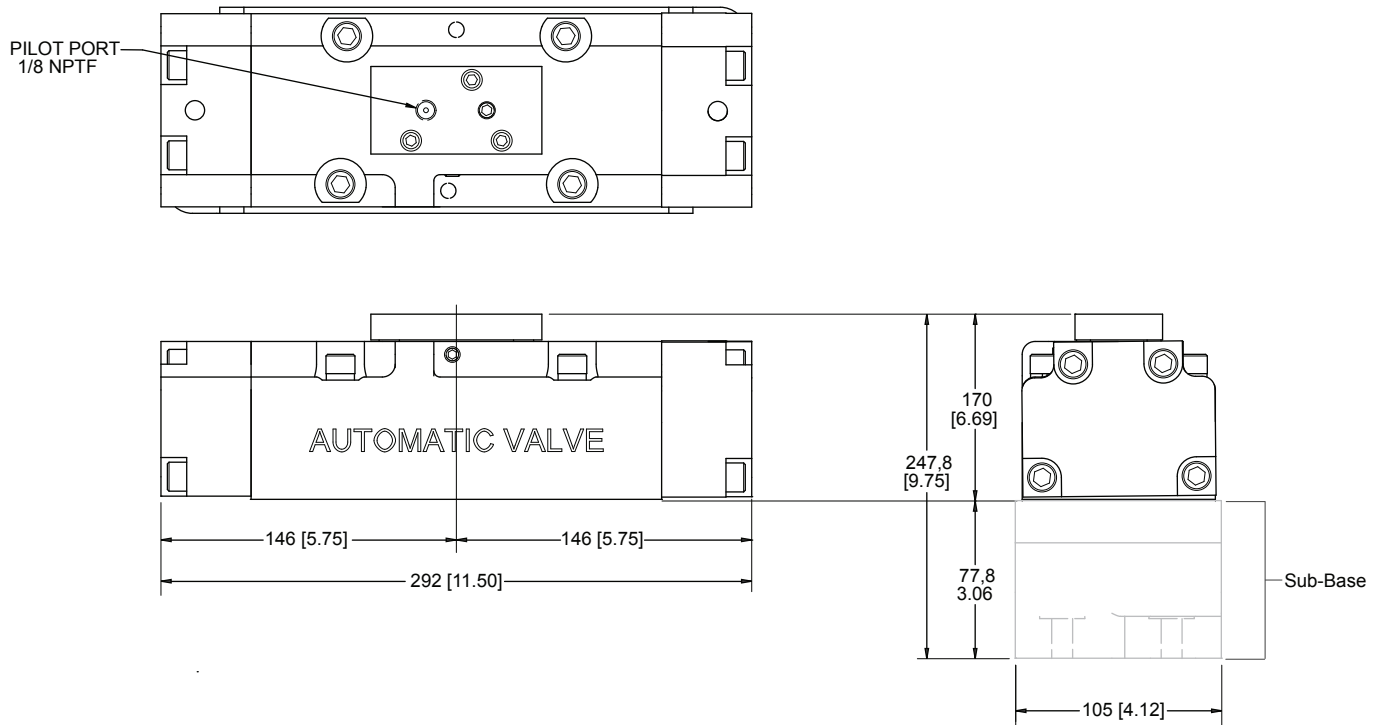

### A20 (1000 Series) - Double

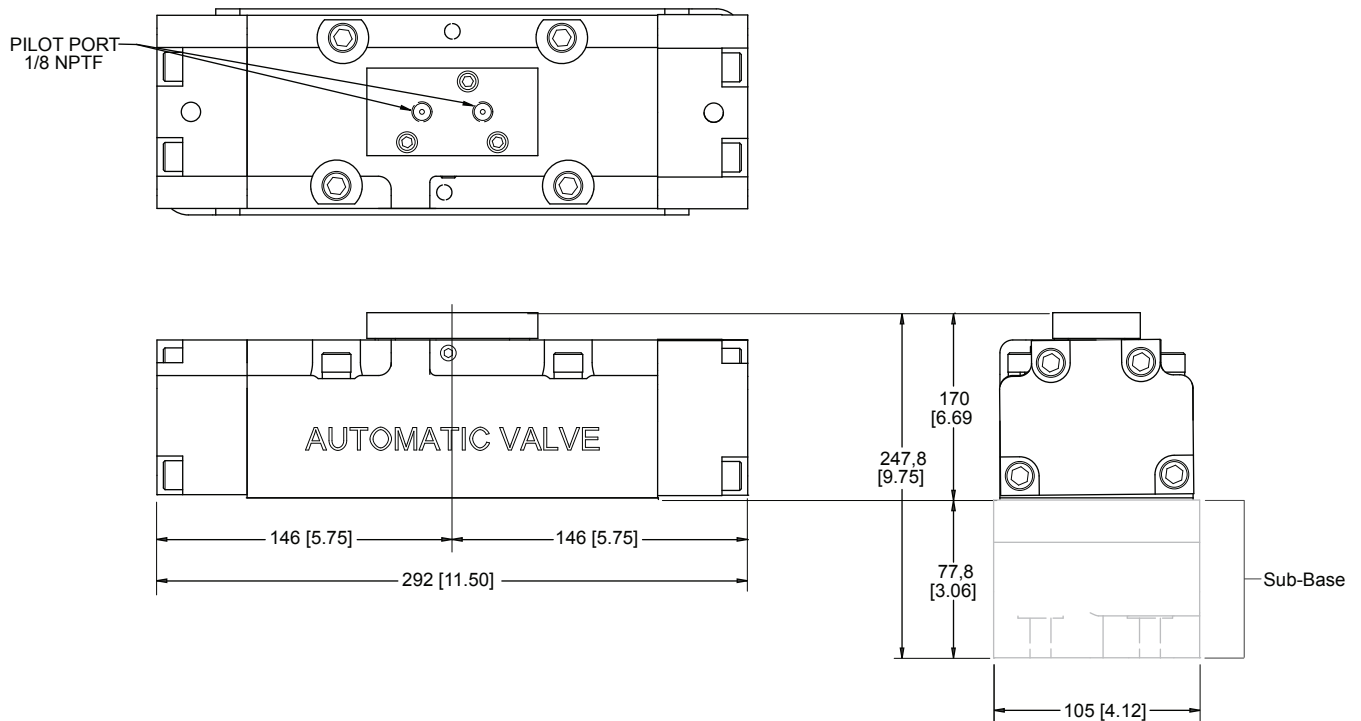

Units of Measure: Top - mm, Bottom - inches

F



# SAE Spool Valves Manual



**A04 (125 Series)**

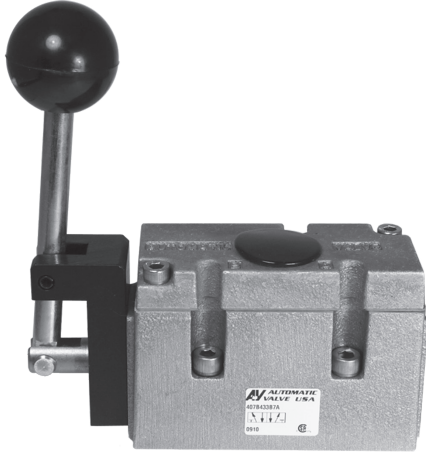

407B433B7A

**A06 (250 Series)**

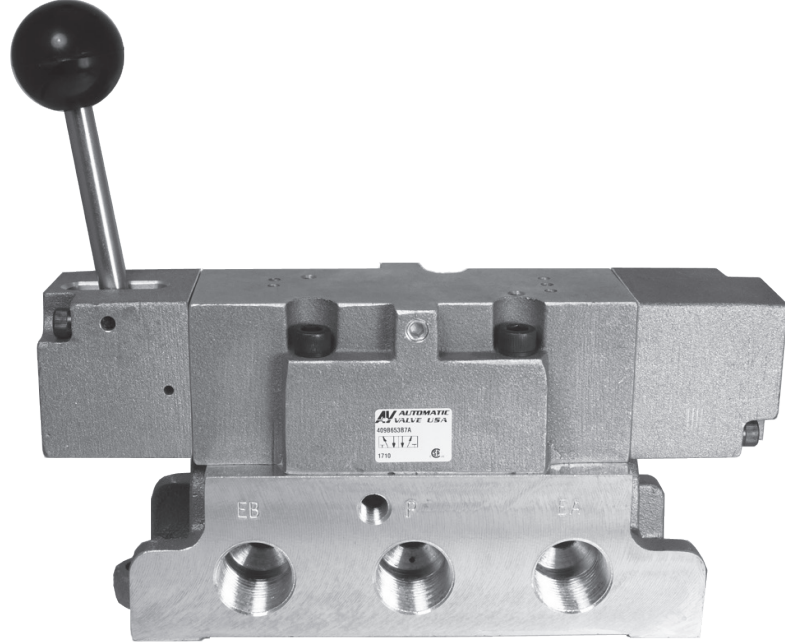

409B673B7A

## Model Numbers

	Body Type	Port Loc'n	Port Size	Flow (5/2) l/min (Cv)	Operator	5/2		Material		Wt Kg (lb)
						Detented	Spring Return	Body	Seal	
<b>F</b> <b>A04</b>	Valve Only	Base	-	2360 (2.4)	Hand Lever Line Mounted	<b>407B433B7A</b>	<b>407B433B9A</b>	Aluminum	NBR	1,0 (2.3)
	Valve + Sub-Base		1/4			<b>409B423B7A</b>	<b>409B423B9A</b>			1,4 (3.2)
	Valve + Manifold (Bottom Cyl Ports)		3/8			<b>413B433B7A</b>	<b>413B433B9A</b>			1,5 (3.3)
	Valve + Manifold (Bottom/Side Cyl Ports)		3/8			<b>416B433B7A</b>	<b>416B433B9A</b>			1,7 (3.7)
<b>A06</b>	Valve Only	Base	-	8460 (8.6)	Hand Lever Line Mounted	<b>407B673B7A</b>	<b>407B673B9A</b>	Aluminum	NBR	3,1 (6.9)
	Valve + Sub-Base		1/2			<b>409B653B7A</b>	<b>409B653B9A</b>			4,3 (9.6)
			3/4			<b>409B673B7A</b>	<b>409B673B9A</b>			
			1			<b>409B603B7A</b>	<b>409B603B9A</b>			
	Valve + Manifold (Bottom Cyl Ports)		1/2			<b>413B653B7A</b>	<b>413B653B9A</b>			3,9 (8.7)
			3/4			<b>413B673B7A</b>	<b>413B673B9A</b>			



# SAE Spool Valves Manual

5/3

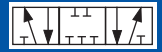

SAE Spool Valves

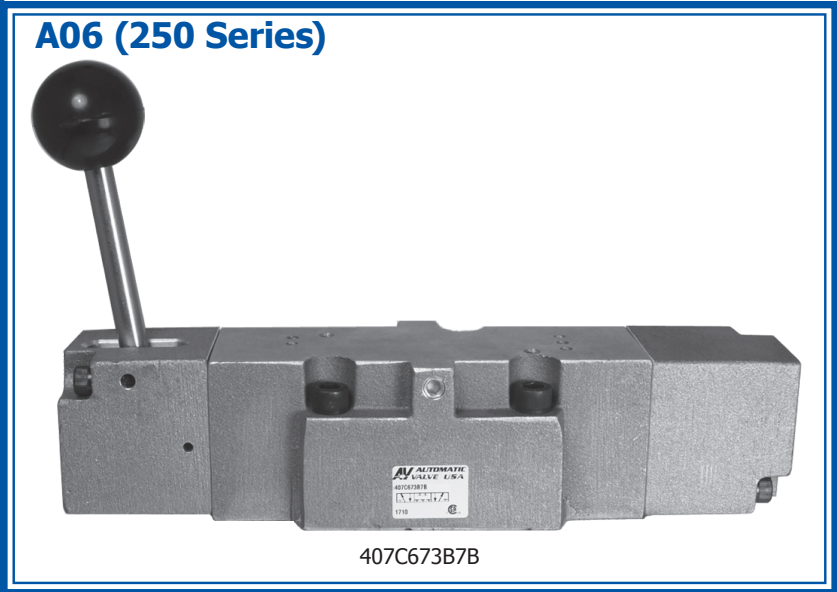
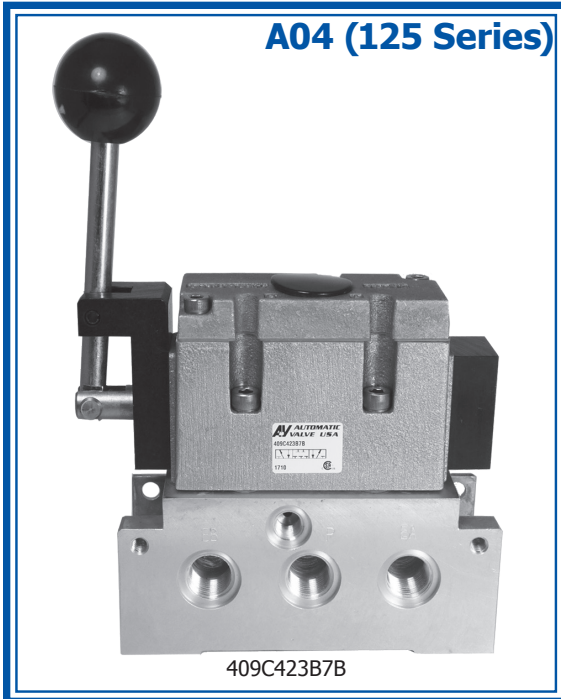

## Model Numbers

Series	Body Type	Port Size	Flow 5/3 l/ min (Cv)	Operator	5/3 (4 Way 3 Position)						Materials	Weight kg (lb)
					Detented			Spring Center				
					Block 	Exhaust 	Pressure 	Block 	Exhaust 	Pressure 		
A04	Valve only	-	2360 (2.4)	Hand Lever, Line Mounted	407C433B7B	407D433B7B	407E433B7B	407C433B9B	407D433B9B	407E433B9B	Body = NBR Seal = NBR	1,0 (2.3)
	Valve + Sub-Base	1/4			409C423B7B	409D423B7B	409E423B7B	409C423B9B	409D423B9B	409E423B9B		1.4 (3.2)
	Valve + Manifold (Bottom Cyl Ports)	3/8			413C433B7B	413D433B7B	413E433B7B	413C433B9B	413D433B9B	413E433B9B		1,5 (3.3)
	Valve + Manifold (Bottom/Side Cyl Ports)	3/8			416C433B7B	416D433B7B	416E433B7B	416C433B9B	416D433B9B	416E433B9B		1,7 (3.7)
A06	Valve Only	-	8460 (8.6)	Hand Lever, Line Mounted	407C673B7B	407D673B7B	407E673B7B	407C673B9B	407D673B9B	407E673B9B	Body = Aluminum Seal = NBR	3,1 (6.9)
	Valve + Sub-Base	1/2			409C653B7B	409D653B7B	409E653B7B	409C653B9B	409D653B9B	409E653B9B		4,3 (9.6)
		3/4			409C673B7B	409D673B7B	409E673B7B	409C673B9B	409D673B9B	409E673B9B		
		1			409C603B7B	409D603B7B	409E603B7B	409C603B9B	409D603B9B	409E603B9B		
	Valve + Manifold (Bottom Cyl Ports)	1/2			413C653B7B	413D653B7B	413E653B7B	413C653B9B	413D653B9B	413E653B9B		3,9 (8.7)
		3/4			413C673B7B	413D673B7B	413E673B7B	413C673B9B	413D673B9B	413E673B9B		

F

5/2



5/3



# SAE Spool Valves Manual



## Dimensional Information

### A04 (125 Series) Hand Lever

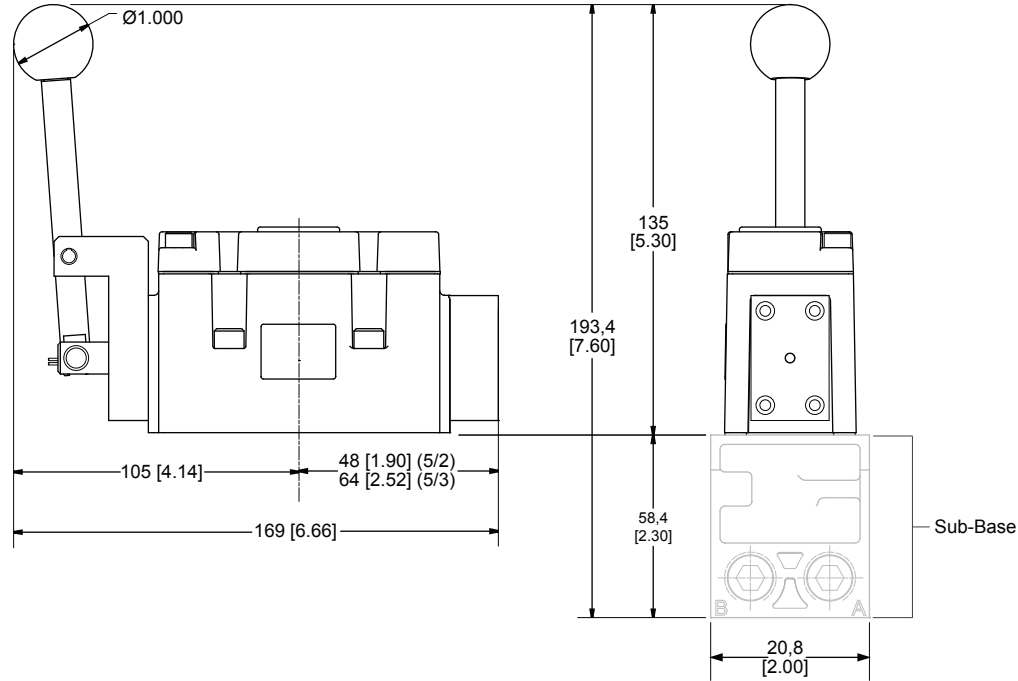

### A06 (250 Series) Hand Lever

F

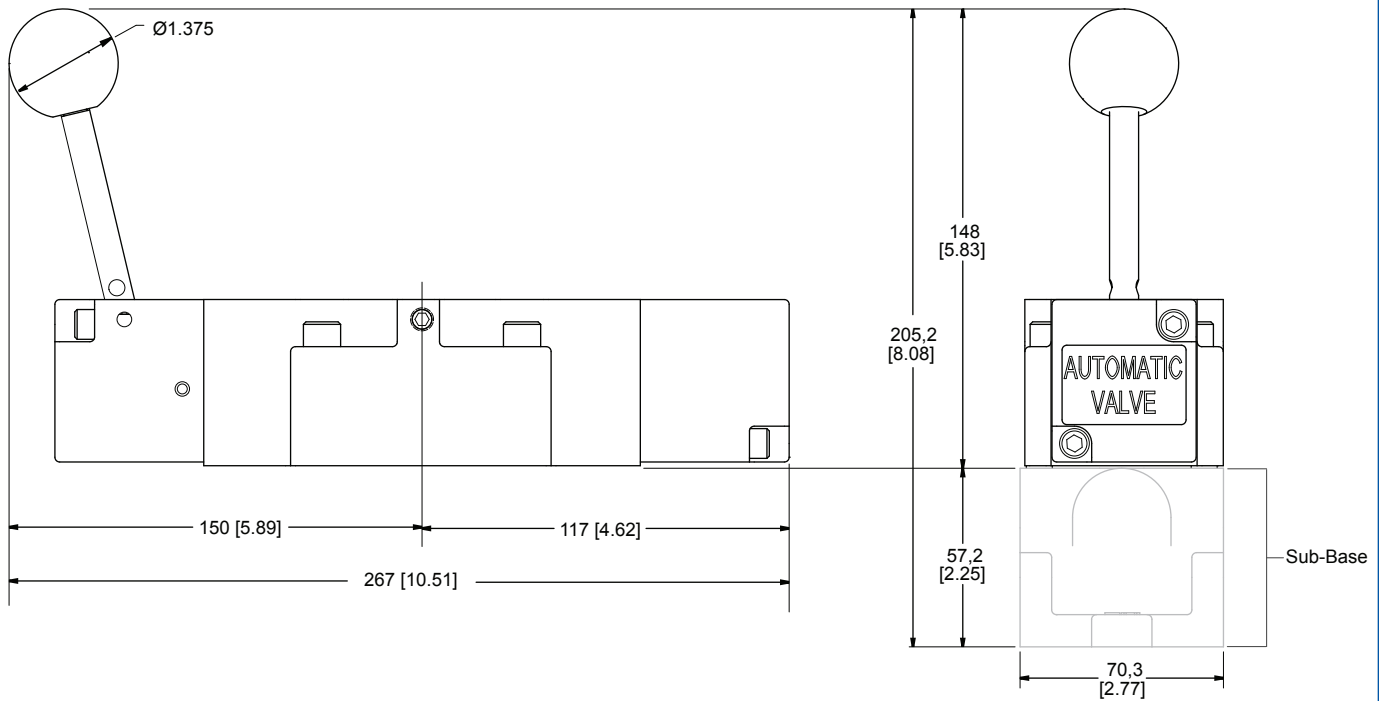

Units of Measure: Top - mm, Bottom - inches



# SAE Spool Valves Sub-Bases & Manifolds

5/2



5/3

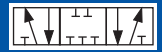

SAE Spool Valves

## Sub-Bases (409)

A04



A6318-025

A06

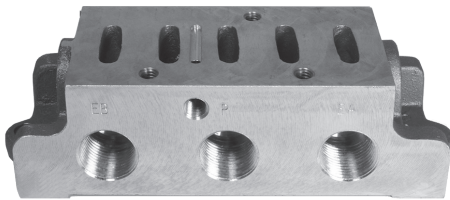

A6331-075

A20

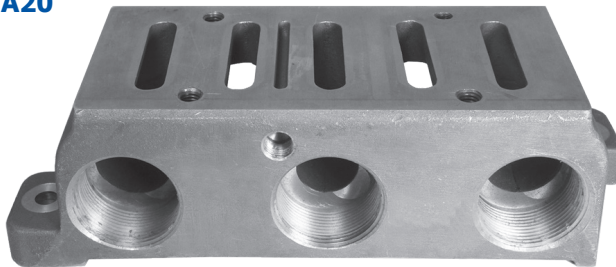

A5247-150

## Manifolds (413 & 416)

A04

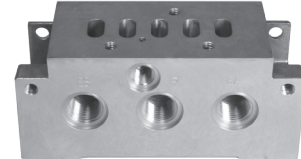

A6250-038 (413)  
A6880-120 (416)

A06 (413)

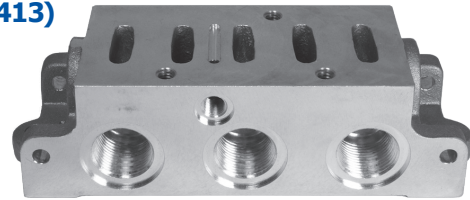

A6265-075

A06 (416)

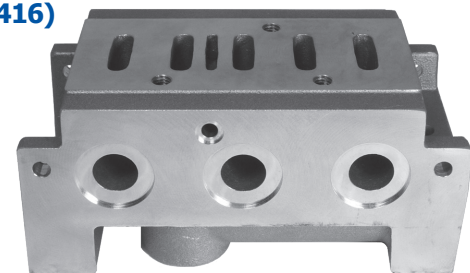

A6886-120

F

## Model Numbers

SAE AV Series	Automotive Series	409		413				416						
		Individual Sub-Base		Manifold <sup>1</sup> Bottom Cylinder Ports		Manifold Accessories		Manifold <sup>1</sup> Bottom/Side Cylinder Ports		Manifold Accessories				
		409 Model Numbers	Cyl Port Size	413 Model Numbers	Port Size		Blocking Disk	Blank Station Covers <sup>2</sup>	416 Model Numbers	Port Size		Blocking Disk	Blank Station Covers <sup>2</sup>	End Plate Kit
			P EA EB	A B		P EA EB			A B					
A04	125	A6318-025	1/4	A6250-038	3/8	3/8	0957-038	A6658	A6880-120	3/8	3/8	A7002-010	A6658	-
A06	250	A6331-050	1/2	A6265-050	1/2	1/2	0957-075	A5903	A6886-120	3/4	1/2	A7002-020	A5903	B6891
		A6331-075	3/4	A6265-075	3/4	3/4			A6886-130	3/4	3/4			
		A6331-100	1											
A20	1000	A5247-125	1 1/4	-	-	-	-	-	-	-	-	-	-	-
		A5247-150	1 1/2											

<sup>1</sup> Seals and mounting hardware are included

<sup>2</sup> Each Blank Station requires a cover.

5/2



5/3

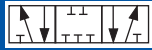

# SAE Spool Valves Sub-Bases & Manifolds



## Dimensional Information

### A04 Sub-Base (409)

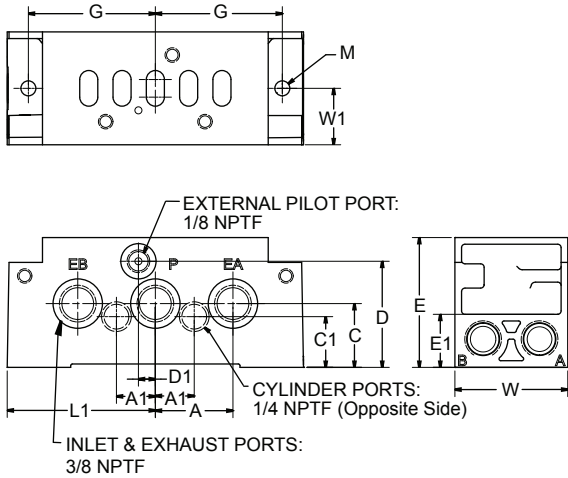

### A06 Sub-Base (409)

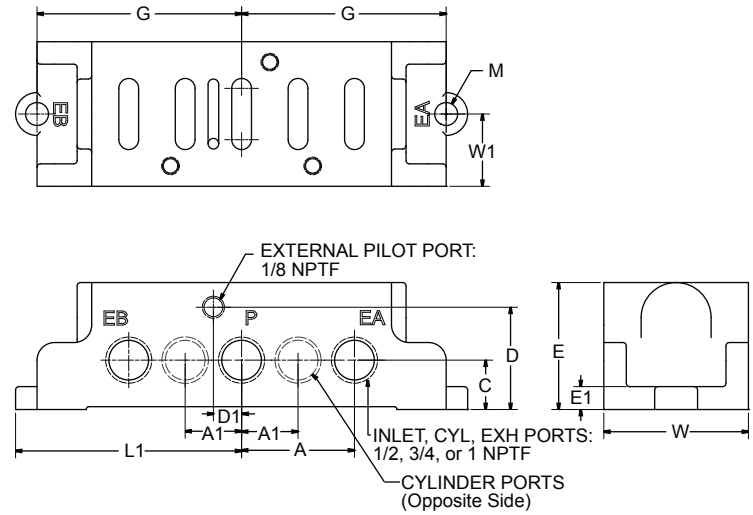

### A20 Sub-Base (409)

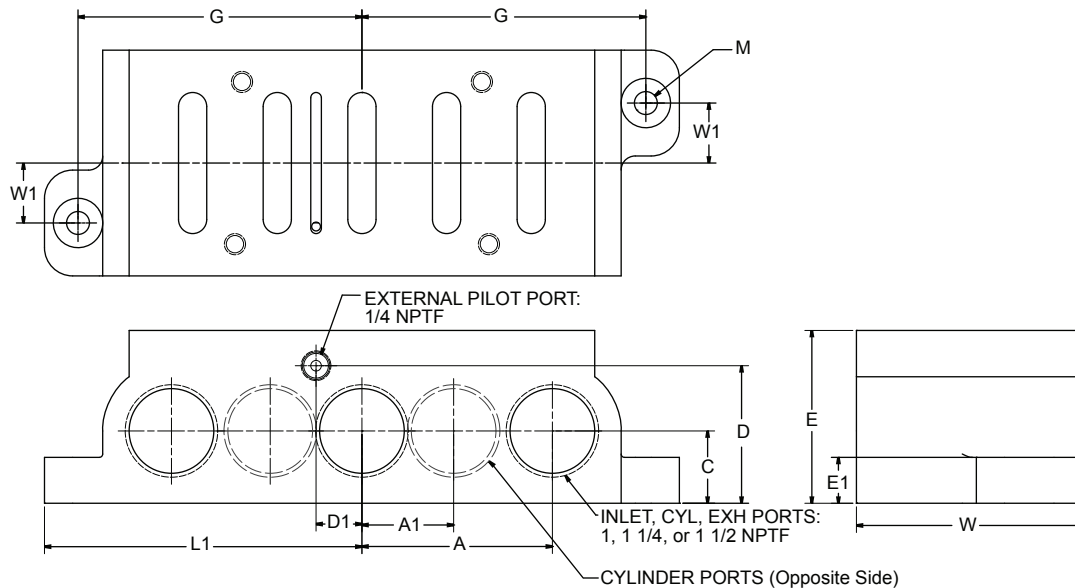

F

Series	Model	A	A1	C	C1	D	D1	E	E1	G	L1	M	W	W1
<b>A04 (125)</b>	409	35,1 1.38	175 0.69	28,7 1.13	22,9 0.90	47,8 1.88	7,62 0.30	58,4 2.30	23,9 0.94	57,2 2.25	66,68 2.63	6,6 0.26	50,8 2.00	25,4 1.00
<b>A06 (250)</b>	409	50,8 2.00	25,4 1.00	22,2 0.88	-	46,0 1.81	12,7 0.50	57,2 2.25	10,3 0.41	92,1 3.63	91,95 3.63	10,2 0.41	70,3 2.77	35,1 1.38
<b>A20 (1000)</b>	409	85,7 3.38	41,3 1.63	3,25 1.28	-	61,9 2.44	20,6 0.81	77,8 3.06	20,6 0.81	128 5.03	143 5.62	10,3 0.41	105 4.12	26,9 1.06

Units of Measure: Top - mm, Bottom - inches



# SAE Spool Valves Sub-Bases & Manifolds

5/2



5/3

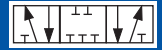

SAE Spool Valves

## Dimensional Information

### A04 Manifold (Bottom Cylinder Ports) (413)

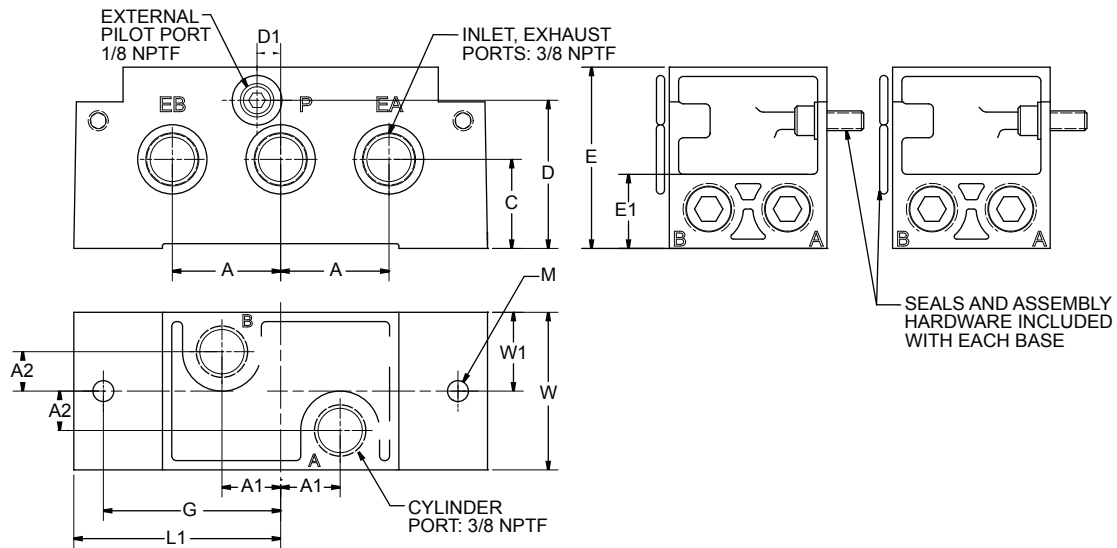

### A06 Manifold (Bottom Cylinder Ports) (413)

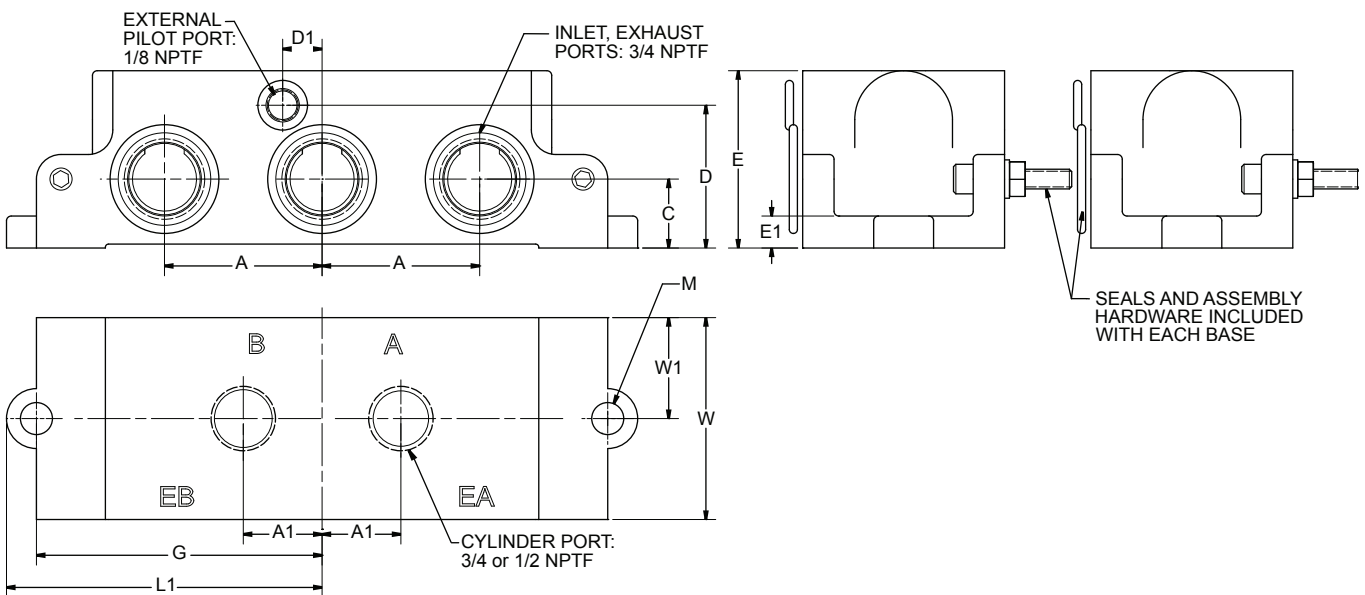

F

Series	Model	A	A1	A2	C	D	D1	E	E1	G	L1	M	W	W1
<b>A04 (125)</b>	413	35,1 1.38	19,1 0.75	12,7 0.50	28,7 1.13	47,8 1.88	7,62 0.30	58,4 2.30	23,9 0.94	57,2 2.25	66,5 2.62	6,6 0.26	50,8 2.00	25,4 1.00
<b>A06 (250)</b>	413	50,8 2.00	25,4 1.00	22,2 1.88	50,8 2.00	71,5 2.81	12,7 0.50	82,6 3.25	10,3 0.41	79,4 3.12	88,9 3.50	8,7 0.34	88,9 3.50	44,5 1.75

Units of Measure: Top - mm, Bottom - inches

# SAE Spool Valves Sub-Bases & Manifolds



## Dimensional Information

### A04 Manifold (Bottom/Side Cylinder Ports) (416)

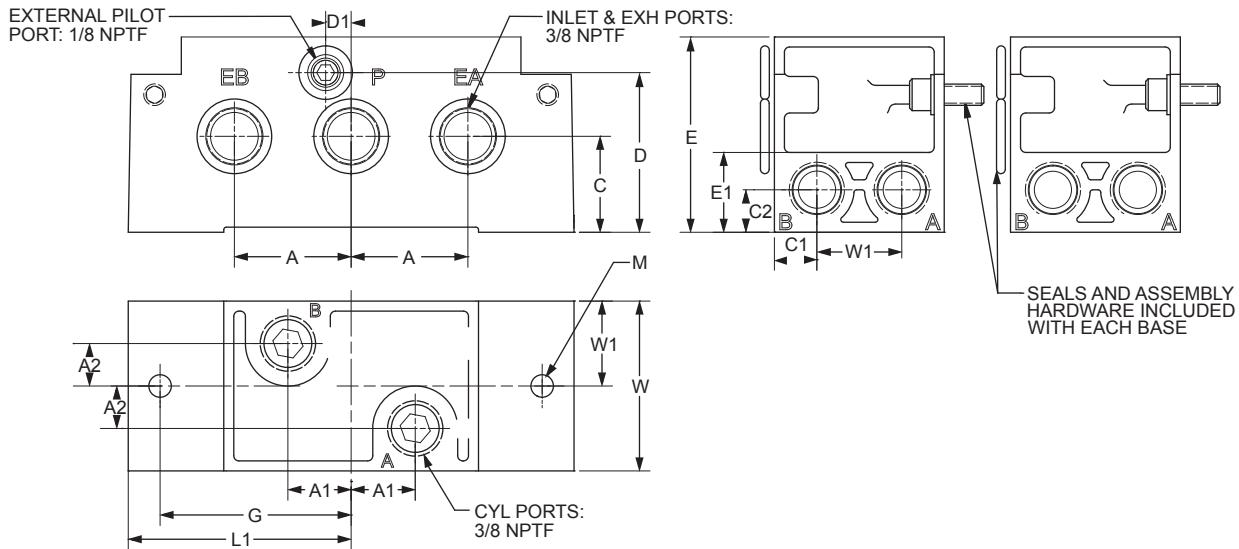

### A06 Manifold (Bottom/Side Cylinder Ports) (416)

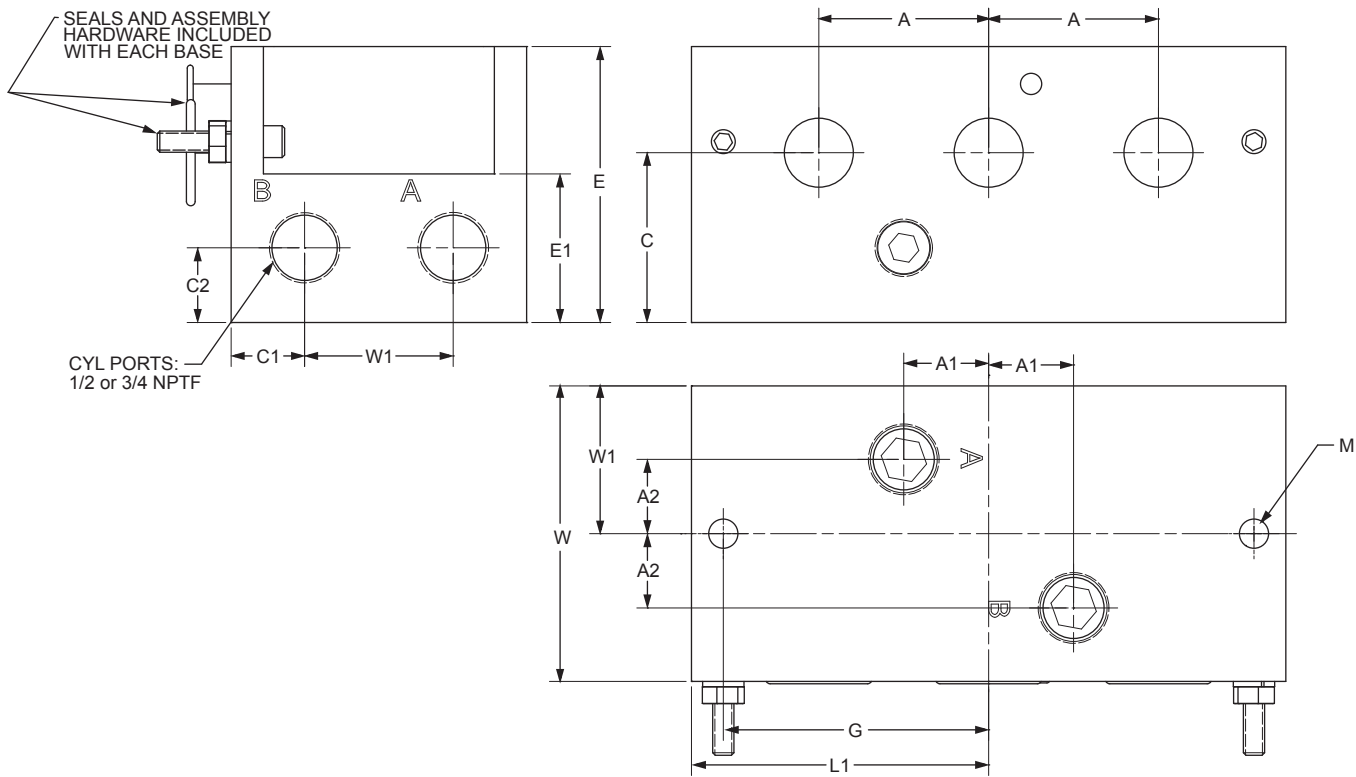

F

Series	Model	A	A1	A2	C	C1	C2	D	D1	E	E1	G	L1	M	W	W1
<b>A04 (125)</b>	416	34,9 1.38	18,9 0.75	12,7 0.50	28,7 1.13	12,7 0.50	12,7 0.50	47,8 1.88	7,62 1.30	58,4 2.30	23,9 1.94	57,2 2.25	66,7 2.62	6,73 0.26	50,8 2.00	25,4 1.00
<b>A06 (250)</b>	416	50,8 2.00	25,4 1.00	22,2 0.88	50,8 2.00	22,2 0.88	22,2 0.88	46,0 1.81	12,7 0.50	82,6 3.25	44,5 1.75	79,4 3.12	88,9 3.50	8,73 0.34	88,4 3.48	44,2 1.74

Units of Measure: Top - mm, Bottom - inches



# SAE Spool Valves Options & Accessories

5/2



5/3

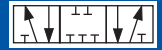

SAE Spool Valves

## Options (Add the suffix to the end of the Model Number in alpha-numeric order)

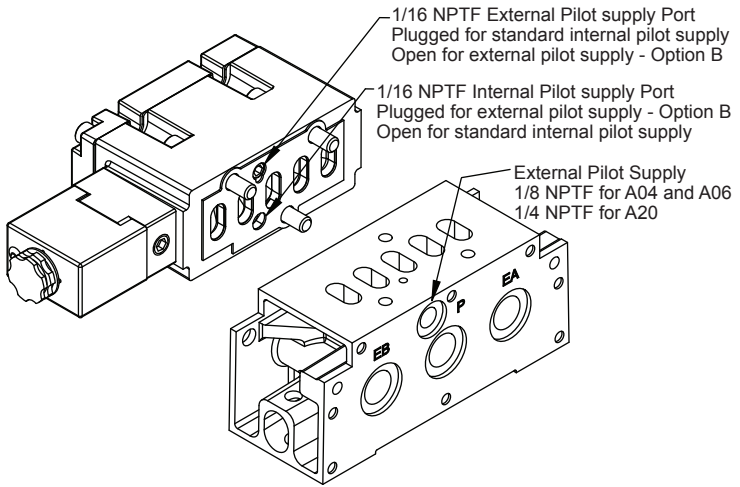
Suffix	Option	Description
<b>A</b>	<b>Fluoroelastomer Seals</b>	For applications where fluid media or ambient conditions are not compatible with nitrile seals. <i>Note: Fluorocarbon seals do not increase the effective temperature range of the valve.</i> <i>For high temperature applications, consult the factory.</i> (Available for A04 and A06 Only)
<b>B</b>	<b>External Pilot</b>	For solenoid applications where the pressure to port one is less than 2 BAR (35 PSIG). See example below for field conversion.
		<p style="text-align: center;"><b>Field Conversion</b></p>  <ul style="list-style-type: none"> <li>Remove the valve from the sub-base and turn upside down.</li> <li>Remove the 1/16 NPTF pipe plug from the external pilot supply port in the valve and install it in the supply port.</li> <li>Connect the air supply to the external pilot supply port in the base.</li> </ul>
<b>D</b>	<b>Dustproof</b>	For applications in extremely dusty and contaminated environments. Vent ports are plugged and spring pad breather vent is eliminated.
<b>Y</b>	<b>Explosion-Proof Coil (CSA, FM)</b>	Refer to the "Electrical Information" page in this section for details.
<b>0</b>	<b>GM - 5 Pin Micro</b>	Customer Specification for Connector Wiring. For more information see the Wiring Chart on the Service Information page in this section.
<b>1</b>	<b>Ford - 5 Pin Micro</b>	
<b>2</b>	<b>Chrysler - 5 Pin Micro AC/DC</b>	
<b>3</b>	<b>GM - 5 Pin Mini</b>	
<b>4</b>	<b>Ford - 5 Pin Mini</b>	
<b>5</b>	<b>Chrysler - 5 Pin Mini</b>	
<b>6</b>	<b>GM - 4 Pin Micro DC</b>	
<b>7</b>	<b>Ford - 4 Pin Micro DC</b>	

F

## Accessories

### Interposed Flow Control

- Restricts air flow from Port A to Port EA and from Port B to Port EB.
- Mounts between the valve and the sub-base or between the valve and the single pressure regulator.
- Vibration-proof metering control
- Interposed Flow Controls cannot be used with Interposed Dual Pressure Regulators.

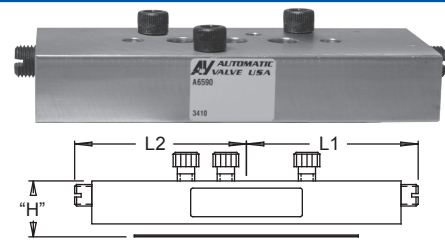
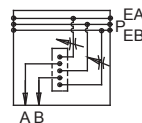

AV Series (SAE)	Model Number	Weight	Dimensions		
		Kg (lb)	H	L1	L2
<b>A04 (125)</b>	<b>A6590</b>	0,3 (0.7)	19,8 (0.78)	63,5 (2.50)	63,5 (2.50)

5/2



5/3

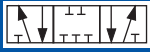

# SAE Spool Valves Accessories



## Sandwich Single Pressure Regulator

### Features

- Regulates single inlet pressure from Inlet Port P to Cylinder Ports A & B.
- Mounts between the valve and sub-base.
- Two Pressure Ranges: 0,6-4,1 BAR (5-60 PSIG); and 0,7-9,0 BAR (10-130 PSIG).
- 1/8 NPTF gage port.
- On series A04, color coded locking rings identify the pressure range: Yellow 5-60PSIG; Red 10-130PSIG.
- In series A06 the fingertip control knob and locking nut are standard.
- If pressure is less than 2 BAR (35 PSIG), then valve must be externally piloted [3,4 BAR (50 PSIG) for 3 position valves].

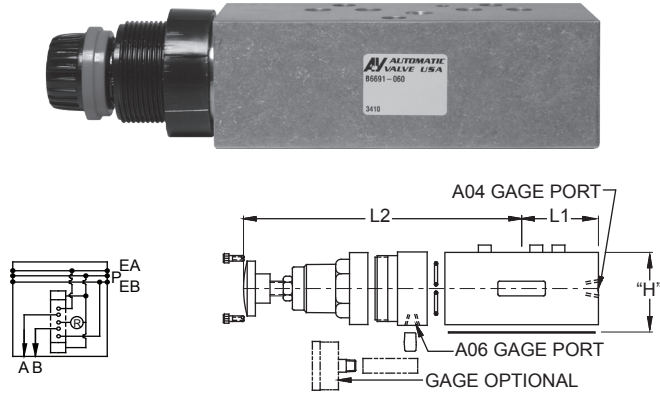

AV Series (SAE)	Type	Model Number		Weight Kg (lb)	Dimensions (top-mm; bottom-inches)		
		5-60 PSIG	10-130 PSIG		H	L1	L2
A04 (125)	Regulator	B6691-060	B6691-130	0,5 (1.2)	37,3 1.47	54,9 2.16	107 4.25
	Gage	A5655-060	A5655-160	-	-	-	-
A06 (250)	Regulator	B6693-060	B6693-130	1,5 (3.5)	63,5 2.5	66,7 2.63	208 8.23
	Gage	A6785-060	A6785-160	-	-	-	-

## Sandwich Dual Pressure Regulator

F



### Features

- Regulates dual inlet pressure from EA - EB to cylinder ports A & B.
- Mounts between the valve and sub-base.
- Two Pressure Ranges: 0,3-4,1 BAR (5-60 PSIG); and 0,7-9,0 BAR (10-130 PSIG).
- 1/8 NPTF gage port.
- On series A04, color coded locking rings identify the pressure range: Yellow 5-60; Red 10-130 PSIG.
- In series A06 the fingertip control knob and locking nut are standard.
- Dual Pressure Regulators require a valve external pilot supply and cannot be used with sandwich flow controls.

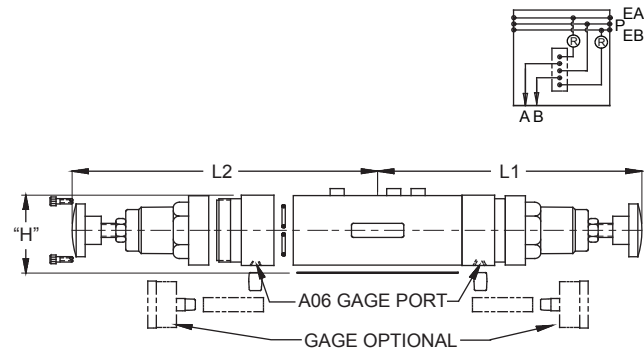

AV Series (SAE)	Type	Model Number		Weight Kg (lb)	Dimensions (top-mm; bottom-inches)		
		5-60 PSIG	10-130 PSIG		H	L1	L2
A04 (125)	Regulator	-	B6692-130-130	0,6 (1.3)	37,3 1.47	108 4.25	108 4.25
	Gage	-	-	-	-	-	-
A06 (250)	Regulator	-	B6694-130-130	2,6 (5.6)	63,5 2.50	208 8.23	208 8.23
	Gage	A6785-060	A6785-130	-	-	-	-



# SAE Spool Valves Electrical Information

5/2



5/3



SAE Spool Valves

## Part Numbers

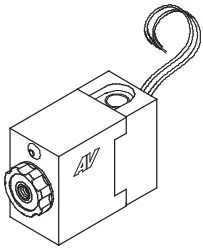
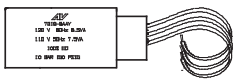
Description	Operator Type	Instructions	Kg (lb)	Coil Part Number **=Voltage
<b>Weather-Proof</b> 18" Leads NEMA 4X 	<b>S</b>	Coil included (specify voltage code from table below)	0,12 (0.27)	<b>A7201-**</b>
<b>Explosion-Proof</b> 1/2" Conduit with 24" Leads CSA & FM Approved CL. I; Zone1 ExmIIT4; AExmII CL. I; Div.1; GR. A, B, C, D CL. II; GR. E, F, G CL. III T4 Ta=-20°C to +60°C NEMA 4, 4X, 7C, 7D, 9 	<b>Y</b>	Coil included (specify voltage code from table below)	0,20 (0.44)	<b>7019-9**Y</b>

## Voltage Codes

** Code	Voltage +/-10%		Current (Amps)				Resistance (OHMS @ 25°C)		Power (AC=VA, DC=Watts)	
			Inrush		Holding					
	Operator Type:		<b>S</b>	<b>Y</b>	<b>S</b>	<b>Y</b>	<b>S</b>	<b>Y</b>	<b>S</b>	<b>Y</b>
	NEMA		NEMA							
4	7, 9	4	7, 9	4	7, 9	4	7, 9	4	7, 9	
<b>AA</b>	120/50 120/60	120/60	.07	.10	.05	.05	908	530	6.9	6.5
<b>AB</b>	240/50 240/60	240/60	.15	.05	.13	.03	3630	2345	6.9	6.8
<b>DA</b>	12 VDC	12 VDC	.37	.38	.37	.38	33	32	4.4	4.5
<b>DB</b>	24 VDC	24 VDC	.18	.19	.18	.19	130	128	4.4	4.5
<b>AB</b>	125 VDC	-	.03	-	.03	-	3630	-	4.8	-
<b>DE</b>	-	125 VDC	-	.04	-	.04	-	2820	-	5.5

F

## Connectors

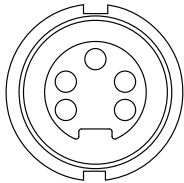
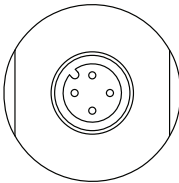
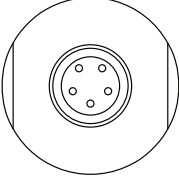
			
<b>Type</b>	5 pin mini	4 pin micro	5 pin micro
<b>Connection</b>	1/2-14-NPT	M12x1	M12x1
<b>Options</b>	3, 4, 5	6, 7	0, 1, 2
<b>Part Number</b>	<b>6095</b>	<b>6095-002</b>	<b>6095-003</b>

5/2



5/3

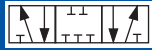

# SAE Spool Valves Service Information



## Wiring

Options					Pin Number									
4 pin Micro	5 Pin Micro	5 Pin Mini	Cst.	Schematic [For SGL Solenoid use Sol B pinout] (See next Page for Wiring & Service Diagram)	1		2		3		4		5	
					Lead	Con-nects To	Lead	Con-nects To	Lead	Con-nects To	Lead	Con-nects To	Lead	Con-nects To
-	0	-	GM		Red/ White	Sol A Brown	Red	Sol B Black	Green	Ground	Red/ Yellow	Sol B Brown	Red/ Black	Sol A Black
-	1	-	Ford		Red/ White	Sol B Brown	Red	Sol A Black	Green	Ground	Red/ Yellow	Sol A Brown	Red/ Black	Sol B Black
-	2 AC	-	Chrysler		Red/ White	Sol A Brown	Red	Sol A Black	Green	Ground	Red/ Yellow	Sol B Brown	Red/ Black	Sol B Black
-	2 DC	-	Chrysler		Red/ White	Sol A Black	Red	Sol B Black	Green	Ground	Red/ Yellow	Sol A Brown	Red/ Black	Sol B Brown
-	-	3	GM		Red/ White	Sol A Brown	Red	Sol B Black	Green	Ground	Red/ Yellow	Sol B Brown	Red/ Black	Sol A Black
-	-	4	Ford		Red/ White	Sol B Brown	Red	Sol A Brown	Green	Ground	Red/ Yellow	Sol A Black	Red/ Black	Sol B Black
-	-	5	Chrysler		Red/ White	Sol A Brown	Red	Sol A Black	Green	Ground	Red/ Yellow	Sol B Brown	Red/ Black	Sol B Black
6	-	-	GM		Brown	Sol A Brown	White	-	Blue	Sol A Sol B (Black)	Black	Sol B Brown	None	
7	-	-	Ford		Brown	-	White	Sol A Brown	Blue	Sol A Sol B (Black)	Black	Sol B Brown	None	

F



# SAE Spool Valves Service Information

5/2



5/3

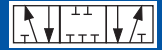

## Wiring & Service Diagram

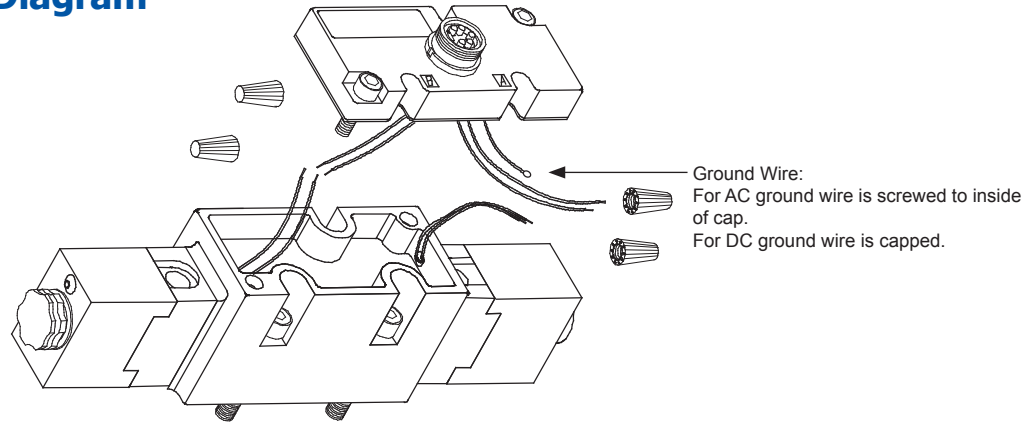

## Assembly: Valve to Manifold Base

### 413 Assembly

Instructions:

- STEP 1: Place O-Rings in counterbores in base.
- STEP 2: Assemble base to base using screws, washers, and nuts.

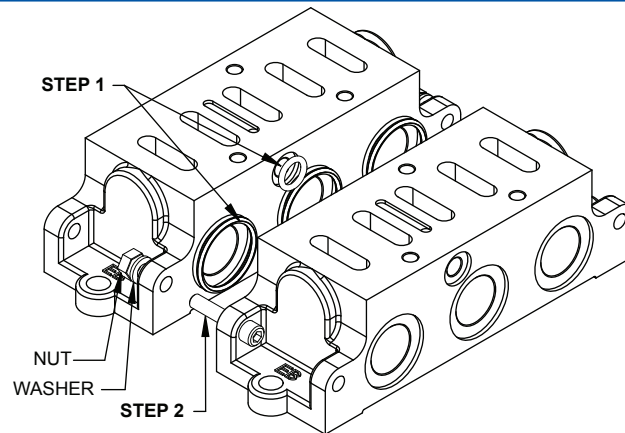

### 416 Assembly

Instructions:

- STEP 1: Place O-Rings in counterbores of end caps.
- STEP 2: Assemble cap to base using screws, washers, and nuts.
- STEP 3: Place O-Rings in counterbores of base.
- STEP 4: Assemble base to base using screws, washers, and nuts.

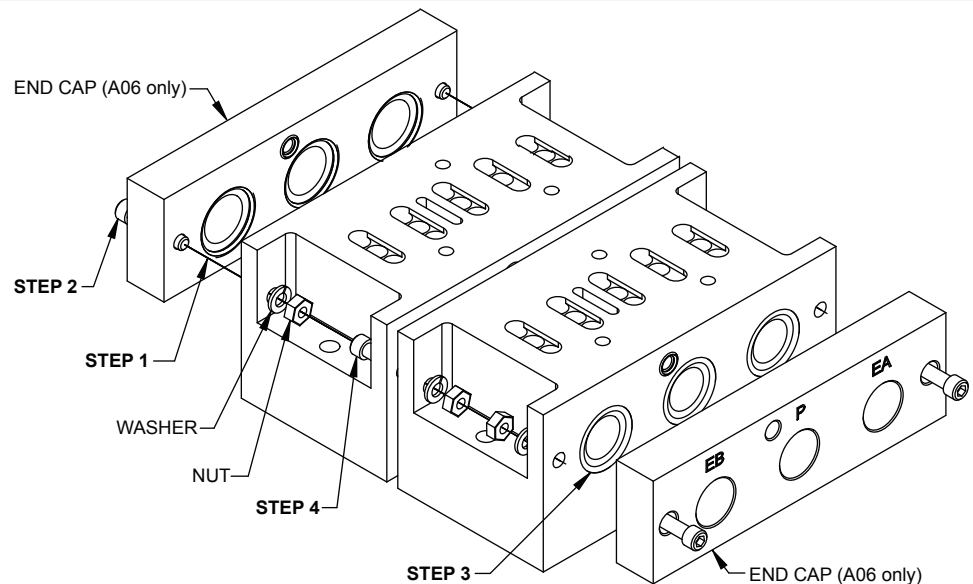

F

5/2



5/3

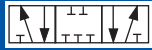

# SAE Spool Valves Service Information



## A04 (125 Series)

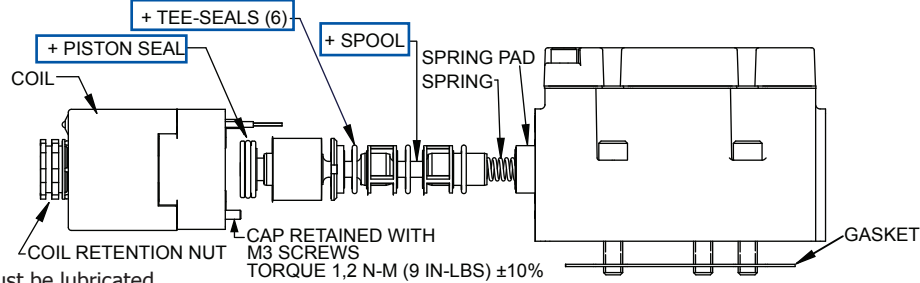

+ = items that must be lubricated

### Service Kit Installation Instructions

1. Follow appropriate lock-out/tag-out procedures. Do not attempt to service a valve, if you are not familiar with lock-out/tag-out procedures.
2. Turn off electrical power to the valve.
3. Remove valve from all electrical and air power sources.
4. Ensure all stored air power is exhausted.
5. Remove coil by first removing coil pretention nut.
6. Remove operator cap by first removing 4 socket head cap screws.
7. Remove existing serviceable components by "pushing" internal components gently out of the valve body.
8. Clean the spool with a clean cloth.
9. Discard the spring (Single Spring Return models only).
10. Lubricate the designated "+" items in above assembly drawing with a thin film of lubricant - the item should look "WET" with no excess lubricant visible.
11. Replace components as shown above.
  - 11.1 Replace spring pad (where required) & spring (Single Spring Return Models Only).
  - 11.2 Alternate Tee-seals and spacers.
  - 11.3 Once all 6 Tee-seals are installed, replace the retainer, bushing & piston, and spool.
12. Orientate the operator cap by aligning the open end of the gasket with the pilot hole in the valve body. (For external pilot, this hole is covered; see Field Conversion on Options Page.)
13. Torque cap screws into body to 1,02 N-m (9 in-lbs)  $\pm 10\%$ . Alternate tightening of the screws, so cap "squeezes" evenly onto body.

**Valve must be disconnected from all air and electrical power sources before disassembly.**

## A06 (250 Series)

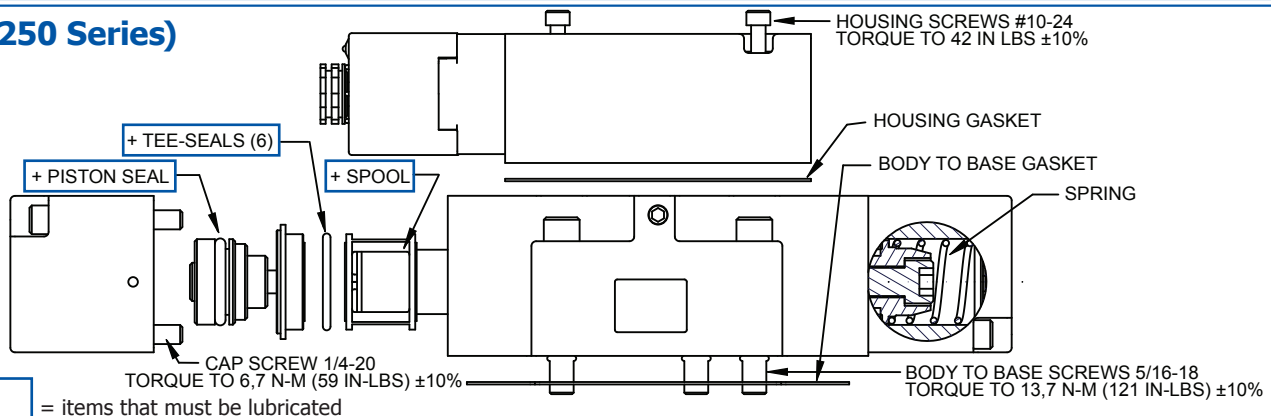

+ = items that must be lubricated

### Service Kit Installation Instructions

1. Follow appropriate lock-out/tag-out procedures. Do not attempt to service a valve, if you are not familiar with lock-out/tag-out procedures.
2. Turn off electrical power to the valve.
3. Remove valve from all electrical and air power sources.
4. Ensure all stored air power is exhausted.
5. Remove end caps by first removing 2 socket head cap screws.
6. Remove existing serviceable components by "pushing" internal components gently out of the valve body.
7. Clean the spool with a clean cloth.
8. Discard the spring (Single Spring Return Models Only).
9. Lubricate the designated "+" items in the above assembly drawing with a thin film of lubricant - the item should look "WET" with no excess lubricant visible.
10. Replace components as shown above.
  - 10.1 Alternate Tee-seals and spacers.
  - 10.2 Once all 6 Tee-seals are installed, insert the retainer and piston into end cap. Insert O-ring in end cap.
  - 10.3 Replace spring (Single Spring Return models only).
11. Orientate spool as shown above.
12. Make sure rubber plug is still present in body. (9A Oper. Only)
13. Orientate the caps by aligning the pilot hole in the valve body with the pilot hole in the cap. (For external pilot, this hole is covered; see Field Conversion on Options Page in this Section.)
14. Torque cap screws into body to 6,7 N-m (59 in-lbs)  $\pm 10\%$ . Alternate tightening of the screws, so that cap "squeezes" evenly onto body.
15. Replace the housing gasket, if necessary. Torque housing screws to 4,8 N-m (42 in-lbs)  $\pm 10\%$ . Take care not to scratch interface surface.
16. Replace the body-to-base gasket, if necessary. Torque body-base screws to 13,7 N-m (121 in-lbs)  $\pm 10\%$ .



# SAE Spool Valves Service Information

5/2



5/3

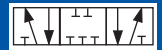

SAE Spool Valves

**Valve must be disconnected from all air and electrical power sources before disassembly.**

## A20 (1000 Series)

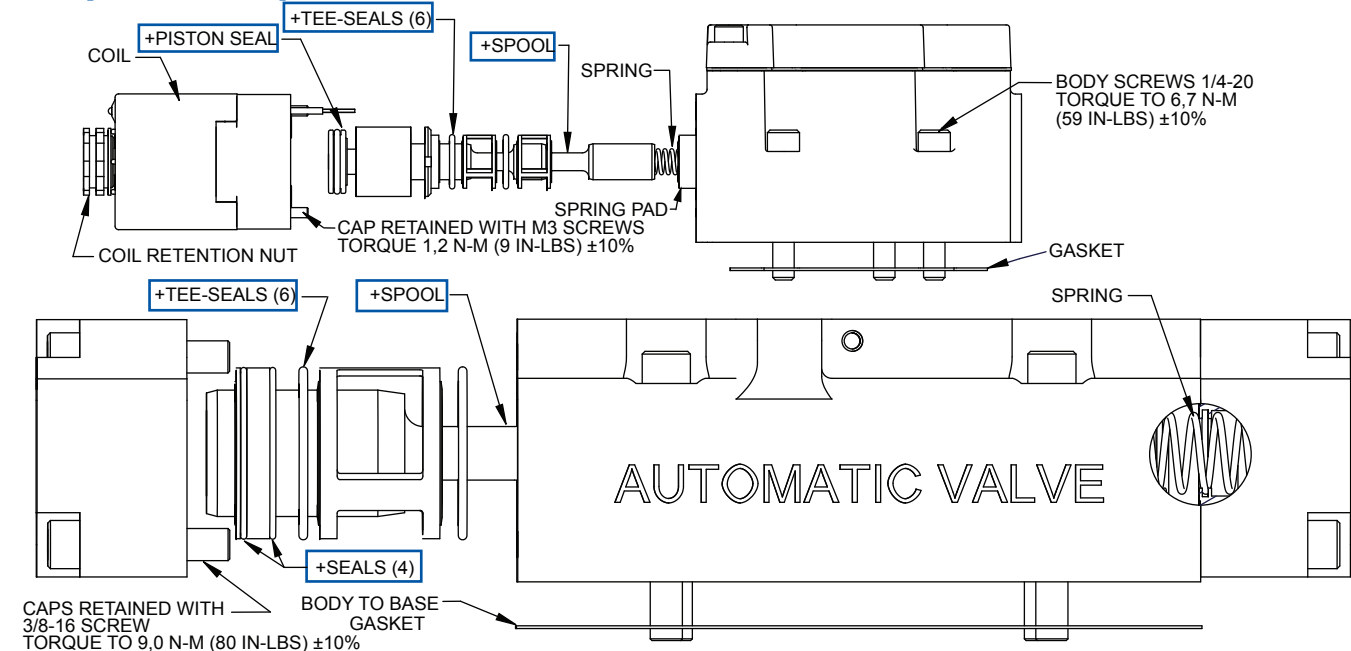

+ = items that must be lubricated

### Service Kit Installation Instructions

1. Follow appropriate lock-out/tag-out procedures. Do not attempt to service a valve, if you are not familiar with lock-out/tag-out procedures.
2. Turn off electrical power to the valve.
3. Remove valve from all electrical and air power sources.
4. Ensure all stored air power is exhausted.
5. Remove plate (for air pilot) or operating valve (A04 for solenoid valves).
6. For solenoid valves follow the Service Kit Installation Instructions for the A04 (see previous page).
7. To service the A20 valve body follow the Service Kit Installation Instructions for the A06 (see previous page), except on Step 14, torque cap screws to 9,0 N-m (80 in-lbs) ±10%.
8. Replace the gasket between the A20 and the plate or A04 operating valve, if necessary. Do not scratch the interface surfaces.
9. Orientate the plate or A04 operating valve to the A20 body by aligning air pilot holes.
10. Torque cap screws into body to 6,7 N-m (59 in-lbs) ±10%. Alternate tightening of so that cap "squeezes" evenly onto body.

**Air Line Lubrication** of Automatic Valve products is not required, but is recommended to maximize service life. Oils should be compatible with seal material, have an ISO 32 or lighter viscosity, and have an aniline point between 82°C (180°F) and 99°C (210°F). Refer to the Maintenance Section of this catalog for recommended lubricants.

## Model Numbers: Service Kits

Series	Function			
	Single		Double	
	Model Number	Contents	Model Number	Contents
A04	K-A04-SGL	Tee-Seals (6), Gasket (1), Piston Seal (1), Spring (1)	K-A04-DBL	Tee-Seals (6), Gasket (1), Piston Seals (2)
	K-A04-SGL-A (fluoroelastamer)		K-A04-DBL-A (fluoroelastamer)	
A06	K-A06-SGL	Tee-Seals (6), Gaskets (2), Piston Seal (1), Spring (1)	K-A06-DBL	Tee-Seals (6), Gaskets (2), Piston Seals (2)
	K-A06-SGL-A (fluoroelastamer)		K-A06-DBL-A (fluoroelastamer)	
A20	K-A20-SGL	Tee-Seals (12), Gaskets(2), Piston Seals(3), Springs(2)	K-A20-DBL	Tee-Seals (12), Gasket(2), Piston Seals (6)



