



Clayton Brake Washer Owners Manual

Owners Manual for all models of Clayton Brake Washers, including bench top, heavy duty truck style, and drum style Brake Washers. Includes detailed operating instructions, maintenance and troubleshooting information.

Revised September 4, 2007

Copyright © Clayton Associates, Inc. 2007

IMPORTANT INFORMATION FOR ALL CLAYTON BRAKE WASHERS

The Clayton Brake Washer provides outstanding protection from exposure to hazardous brake dust and does an excellent job of cleaning brakes, drums and brake parts. Please follow all directions carefully to ensure that the Brake Washer is properly assembled for best results. Failure to follow the proper assembly procedures can cause damage to the pump, regulator, or structural components, and may void warranty.

Explanation of Hazard Symbols



The symbol of a person wearing goggles shows that flying debris or dust may injure the eyes.



The symbol of a person wearing breathing protection shows that airborne dust may be present.



The caution symbol indicates that caution should be used to avoid damage to equipment.



The lifting strain symbol indicates that lifting certain equipment unassisted could cause back injury or strain.

ITEMS OF SPECIAL IMPORTANCE:

The following notes apply to all Clayton Brake Washers:

- DO NOT USE SOLVENTS, MINERAL SPIRITS OR ANY FORM OF COMBUSTIBLE SUBSTANCE IN THIS EQUIPMENT.
- Use ONLY water based cleaners with this equipment.
- To protect technicians from exposure to hazardous brake dust, thoroughly wet the shoes and inside the drum before removing the drum.
- Never use the Brake Washer as a means of disposing of chemicals or solvents.
- The compressed air regulator is factory set and cannot be adjusted. Air pressure up to 15 BAR may be supplied to the regulator.
- Tampering or attempting to adjust the regulator will void the warranty on the regulator and on the pump.
- Never use compressed air to clean the brakes. Hazardous dust may be blown airborne and present a breathing hazard.
- Always maintain adequate solution levels in the Brake Washer to avoid running pump dry.
- While handling the pump, be sure not to damage or break the blue tube protruding from below the pump. Doing so will render the pump inoperable. This blue tube is the compressed air exhaust. Refer to figure 1, Pump Setup Diagram at the back of this manual to ensure proper pump installation.



**INSTRUCTIONS FOR DRUM-STYLE BRAKE WASHERS
BCE-300, BCE-350S, BCE-500**



PREPARATION

- Remove the metal strips from the bottom of the washer. Save the hardware to attach the casters. Attach the casters to the bottom of the dolly, placing the casters over the metal strip, which strengthens the dolly. NOTE: The metal strips must be used, or the weight of the brake washer will collapse the dolly.
- Place the Oil Magnet™ in the bottom of the tank. Do not cut or open it.
- Place the basin/lid assembly on the tank with the pump positioned to the side of the drum opposite the Clayton Brake Washer label.
- Press firmly down on the lid; pull the strap out slightly so the lid will snap in place around the top of the drum. Continue applying pressure around the top of the drum to complete the seal.
- Refer to Figure 1 at back of manual for pump setup diagram.
- Take braided hose from the regulator and insert the quick-disconnect fitting into the pump in the receptacle designated as “GAS IN”. Slide the tab in place to secure the fitting.
- Take supply hose from the tank and insert the quick-disconnect fitting into the pump in the receptacle designated as “PRODUCT IN”. Slide the tab in place to secure the fitting.
- Insert the quick-disconnect fitting on the end of the tool hose into pump in the receptacle designated as “PRODUCT OUT”. Slide the tab in place to secure the fitting.
- NOTE: While handling the pump, be sure not to damage or break the blue tube protruding from below the pump. Doing so will render the pump inoperable and void warranty. This blue tube is the compressed air exhaust, and nothing should be attached to it.
- Add water to the fill line.
- Insert the Primary Microfilter. Be sure it fits snugly into the basin by pressing the filter gasket firmly into the filter seat in the bottom of the basin.
- Pour 1 liter of T-N-T Plus™ through the Primary Microfilter. (Pouring through the filter prevents the liquid from splashing).
- NOTE: Wear goggles and gloves when handling the cleaner in its concentrated state.
- Insert a ¼” quick-disconnect plug into the end of the short hose extending from the pressure regulator.
- NOTE: The regulator is factory set and cannot be adjusted. You may use shop air up to 200 P.S.I. to operate the Brake Washer.
- Attach your compressed air line to the machine to power the pump.
- Depress the triggers on both tools to purge air from hoses and to fill them with solution.
- Install the Parts Cleaning Tray. The Super Brake Washer is ready for use.



OPERATION

Disc Brakes:

- Use the Injector Nozzle to saturate the brake pads and rotor. Once the caliper is removed, you can continue to wash the pads and caliper if desired.

Drum Brakes:

- Before striking the drum to loosen it, or before attempting to remove the drum, use the Injector Nozzle to wet the brake shoes and the inside of the drum. The Injector Nozzle is the silver, flexible nozzle.
- For vehicles with adjustment slots, remove the plug, and then use the Injector Nozzle to introduce solution into the drum to wet the brakes.
- If the brakes have no adjustment slot, then use the Injector Nozzle to introduce the solution through the gap between the drum and the backing plate.
- During brake inspections, wet the brakes and drum by injecting solution into the gap between the drum and backing plate, in the area corresponding to 2 to 5 o'clock, and from 7 to 10 o'clock. This will keep the wheel cylinder dry allowing you to make a visual inspection to determine if the cylinder is leaking.
- Once you have thoroughly wetted the brakes and drum, slide the drum back $\frac{1}{2}$ " to 1" and continue flooding the brakes to saturate any dust. This prevents hazardous brake dust from becoming airborne.
- Continue to wet the brakes as the drum is removed. Check to see if the drum is wet inside indicating that you have done a good job wetting the drum to control brake dust.
- With the drum off, if there is no brake fluid visible, wash the cylinder too. If brake fluid is visible, indicating a leaking cylinder, wait to show the customer (to sell the repair job) before cleaning it.
- If you will not be servicing the brakes, allow them to air dry or wipe them dry before replacing the drum. Ride the brakes for a few seconds as you remove the car from the shop. The brakes will then be dry when the customer leaves the premises.

DRYING THE BRAKES (for models with drying gun)



- **AFTER THE BRAKES ARE THOROUGHLY CLEAN**, use the drying gun to dry the brakes and backing plate so you can apply lubricant.
- **NEVER USE THE SAFETY DRYING GUN ON DUSTY BRAKES.** Blowing dirty brakes with compressed air creates a health hazard for technician.

MAINTENANCE

CHANGING THE PRIMARY MICROFILTER

- Change the Primary Microfilter after servicing approximately 150 vehicles or monthly.
- Remove the Primary Microfilter and place it into a plastic bag and dispose of it.
- Remove the Oil Magnet and wring it lightly over the Brake Washer to release cleaning solution. If oil appears at the surface, wring it out into your waste oil receptacle.
- If you do not intend to change the solution, install a new Primary Microfilter and replace the Parts Cleaning Tray.

CHANGING THE CLEANING SOLUTION USING THE SPIGOT (BCE-500 ONLY)

- Change the solution after servicing approximately 450 vehicles or every three months
- Locate the machine over a drain that feeds into the sanitary sewer system. Open the spigot and drain the tank.

CHANGING THE CLEANING SOLUTION USING THE PUMP



- Disconnect the compressed air line.
- Use elastic bands to hold the triggers down. while
- **NOTE:** Do not allow pump to run dry.
- Place the tools into a sanitary sewer drain or sink.
- Connect the compressed air line to begin pumping.
- When the tank level is low enough so that the pump begins to draw air, use a hose to add 1-2 gallons of water to suspend any sediment on the bottom (sediment is normal). Begin pumping the suspended sediment and solution.
- **NOTE:** It is not necessary to thoroughly clean the tank or to drain all dirty water from the tank.
- When finished pumping, release the triggers, install a new Primary Microfilter, and proceed to refill the tank with solution
- Replace the Parts Cleaning Tray.

**INSTRUCTIONS FOR CLAYTON TRUCK BRAKE WASHERS
BCE-400, BCE-410**



PREPARATION

- The Truck Brake Washer is shipped fully assembled. An Oil Magnet™ is in the basin. The Oil Magnet™ will absorb any free oil. A disposable cloth Primary Microfilter is under the grille. A reusable, stainless steel and plastic prefilter rests upon the grille. A black rubber pad serves as a drain pan during cleaning and a cover when the machine is not in use.
- Follow chemical manufacturer's instructions to prepare a working solution of cleaner for the machine. When possible, pour the solution through the filter to fill the basin with 6.5 gallons (25 liters). Pouring through the filter prevents liquid from splashing. When the basin is full, the filter is partially under water.
- Place the stainless wire mesh prefilter on the grille.
- Insert a compressed air quick-disconnect plug (not included) into the hose extending from the pressure regulator. The factory-supplied fitting at the end of the hose is ¼" NPT.
- Attach a compressed air line to the quick disconnect plug.
- Depress the triggers on both tools to purge air from hoses and to fill them with solution.
- The Truck Brake Washer is now ready for use.

OPERATION

Some shops remove the tire and the drum (or drum and hub) in separate operations. Other shops use a wheel dolly to remove them as an assembly in one operation. Use the method that best suits the work performed in your shop.

If your shop removes the tire and the drum in separate operations:



- Remove the tire. Use a dolly or get assistance in lifting heavy tires and wheels.
- Roll the Truck Brake Washer under the drum.
- Before attempting to remove the drum, use the Injector Nozzle to saturate the inside of the drum, wetting the brake shoes and flushing the drum.
- Once you have thoroughly saturated the brakes and drum, slide the drum back 3 to 5 cm. Continue flooding the brakes to suppress any dust that remains.
- Remove the drum
- Use the brush to clean the brakes and the drum.

If your shop removes the tire and the drum (or drum and hub) in one operation:

- Before raising the vehicle, roll the Truck Brake Washer under the axle.
- Place the edge of the black neoprene cover between the drum and wheel with the opposite end resting on the Truck Brake Washer. It will serve as a drain board to channel solution from the drum back into the Truck Brake Washer as you wet the brake parts and drum.
- Use the Injector Nozzle to saturate the inside of the drum, wetting the brake shoes and flushing the drum.
- Remove the Truck Brake Washer from under the vehicle.
- Raise the vehicle and place safety stands under the axle.
- Follow normal shop procedure to remove the tire, drum and hub.
- Use the brush to thoroughly clean the brakes and drum.

DRYING THE BRAKES



- After the brakes are clean, use the yellow drying gun to dry the brakes and backing plate so you can apply lubricant.
- Never use the safety drying gun on dirty brakes. Blowing dirty brakes with compressed air creates a health hazard for technician and others in the shop.

MAINTENANCE

CHANGING THE FILTERS (monthly)

- Lightly wet the prefilter. Tap the filter against the inside of a trashcan to dispose of dirt and debris.
- Lightly wet the Primary Microfilter.
- Remove the grille. Place the Primary Microfilter in a plastic bag and dispose of it.
- Remove the Oil Magnet™ and wring it lightly over the Truck Brake Washer to release cleaning solution. If oil appears at the surface of the Oil Magnet, wring it out into your waste oil receptacle. Replace the Oil Magnet™ in the basin.
- Install a new Primary Microfilter and replace the grille.

CHANGING THE CLEANING SOLUTION (every three months)

NOTE: Consult your local sewer department for regulations pertaining to drain disposal of wastewater in your community. If you follow these instructions, in most areas, wastewater can be poured or pumped into the sanitary sewer or septic tank. Never dispose of solution into the storm sewer.

- Disconnect the compressed air line.
- Use elastic or wire to hold the triggers down while the Truck Brake Washer is being pumped.
- Connect the compressed air line to begin pumping.
- It is not necessary to thoroughly clean the Truck Brake Washer or to drain all the dirty water from it.
- When finished pumping, release the triggers, install a new Primary Microfilter, replace the grille and proceed to refill the tank with solution.

**INSTRUCTIONS FOR MINI BRAKE WASHER
BCE-200**



PREPARATION

- The Oil Magnet is shipped in place on the bottom of the tank.
- The Primary Microfilter is ready for use under the grille.
- Add water into the Mini Brake Washer to a level just under the grille (approximately 3 gallons).
- Pour 10 ounces of T-N-T Concentrated Cleaner through the Primary Microfilter (pouring through the filter prevents liquid from splashing).
- **NOTE:** Wear goggles & gloves when handling the T-N-T Concentrated Cleaner in its concentrated state.
- Insert a ¼" quick disconnect plug into the end of the hose extending from the pressure regulator.



- **NOTE:** The regulator is factory set and cannot be adjusted. You may use shop air up to 200 P.S.I. to operate the Mini Brake Washer.
- Attach your compressed air line to the machine to power the pump.
- Depress the triggers on tool to purge air from hoses and fill with solution.
- The Mini Brake Washer is now ready for use.

OPERATION

Disc Brakes:

- Use the Injector Nozzle to saturate the brake pads and rotor. Once the caliper is removed, you can continue to wash the pads and caliper if desired.

Drum Brakes:

- Before striking the drum to loosen it, or before attempting to remove the drum, use the Injector Nozzle to wet the brake shoes and the inside of the drum. The Injector Nozzle is the silver, flexible nozzle.
- For vehicles with adjustment slots, remove the plug, and then use the Injector Nozzle to introduce solution into the drum to wet the brakes.
- If the brakes have no adjustment slot, then use the Injector Nozzle to introduce the solution through the gap between the drum and the backing plate.
- During brake inspections, wet the brakes and drum by injecting solution into the gap between the drum and backing plate, in the area corresponding to 2 to 5 o'clock, and from 7 to 10 o'clock. This will keep the wheel cylinder dry allowing you to make a visual inspection to determine if the cylinder is leaking.
- Once you have thoroughly wetted the brakes and drum, slide the drum back ½" to 1" and continue flooding the brakes to saturate any dust. This prevents hazardous brake dust from becoming airborne.
- Continue to wet the brakes as the drum is removed. Check to see if the drum is wet inside indicating that you have done a good job wetting the drum to control brake dust.
- With the drum off, if there is no brake fluid visible, wash the cylinder too. If brake fluid is visible, indicating a leaking cylinder, wait to show the customer (to sell the repair job) before cleaning it.
- If you will not be servicing the brakes, allow them to air dry or wipe them dry before replacing the drum. Ride the brakes for a few seconds as you remove the car from the shop. The brakes will then be dry when the customer leaves the premises.

CHANGING THE FILTERS (monthly)

- Lightly wet the Primary Microfilter.
- Remove the grille. Place the Primary Microfilter in a plastic bag and dispose of it.
- Remove the Oil Magnet™ and wring it lightly over the Mini Brake Washer to release cleaning solution. If oil appears at the surface of the Oil Magnet, wring it out into your waste oil receptacle. Replace the Oil Magnet™ in the basin.
- Install a new Primary Microfilter and replace the grille.

CHANGING THE CLEANING SOLUTION (every three months)

NOTE: Consult your local sewer department for regulations pertaining to drain disposal of wastewater in your community. If you follow these instructions, in most areas, wastewater can be poured or pumped into the sanitary sewer or septic tank. Never dispose of solution into the storm sewer.

- Disconnect the compressed air line.
- Use elastic or wire to hold the triggers down while the Truck Brake Washer is being pumped.
- Connect the compressed air line to begin pumping.
- It is not necessary to thoroughly clean the Truck Brake Washer or to drain all the dirty water from it.
- When finished pumping, release the triggers, install a new Primary Microfilter, replace the grille and proceed to refill the tank with solution.

WARRANTY

Clayton Associates, Inc. warrants products of its own manufacture and will either repair or replace all parts that prove defective under normal use for a period of one (1) year. The warranty period shall commence ninety (90) days from the date of manufacture as evidenced by the equipment serial number. In the absence of an equipment serial number, the warranty period will commence ninety (90) days from the date of manufacture of the pump as evidenced by the pump serial number.

This warranty does not cover repairs due to normal wear, accident, neglect, misuse, or use other than as indicated in the instruction booklet. **Disassembling the pump or attempting to adjust the air regulator will void the warranty on both components.**

Clayton will provide parts and labor performed at its factory at no cost to the customer for repair of all equipment returned to the factory at the customer's expense.

Clayton shall not in any event be liable for any damages, loss of production time or profits, whether based on contract, warranty, negligence, strict liability or otherwise, including without limitation any consequential, incidental or special damages, arising with respect to the equipment or its failure to operate. Clayton Associates, Inc. makes no other warranty or representation of any kind, except that of title, and all other warranties, express or implied, including warranties of merchantability and fitness for a particular purpose, are hereby expressly disclaimed.

Brake Washer Troubleshooting:

Problem: Brake cleaning solution does not stop flowing from the injector nozzle or from the flow-thru brush tip.

- You will need to replace whichever tool is causing the problem.
- Remove the tips and fittings from the tools, and order a new fluid gun. This part is just the gun portion, and you'll need to reattach your nozzles or brush tip to the new gun.
- Now is also a good time to replace the injector nozzle or brush tip if they are old or worn.

Parts to order:

- 300-018B Gun only
- 300-045B Injector tip
- 300-012 Brush tip

Problem: Brake cleaning solution flows through tools, but has slowed to a trickle.

- First, check the pickup tube, which is in the bottom of the Brake Washer reservoir. Ensure that the Supply line filter (the small round screen at the end of the pickup tube) is clean and clear. Sometimes, debris in the barrel can clog the pickup tube, reducing flow of solution. If this is the case, replace the supply line filter.
- Next, disconnect the pickup tube from the pump. The tube is held in place by a small tab which slides to the side to release the tube.
- Next, disconnect the air supply line from the pump. This is the smaller tube which runs from the regulator to the pump. Connect the regulator to your shop's air supply. Be sure that there is good air flow out of the regulator. If not, you'll need to replace the regulator.

Parts to order:

- 300-005B Supply line filter
- 300-A078B Liquid Pickup Tube
- 300-009B Regulator

Problem: Brake Washer is not pumping any solution

- First, disconnect the air supply line from the pump. This is the smaller tube which runs from the regulator to the pump. Connect the regulator to your shop's air supply. Be sure that there is good air flow out of the regulator. If not, you'll need to replace the regulator.
- Next, reconnect the air line, and disconnect the tube which goes to your tools. This tube is connected to the pump through the port which reads: Product Out. Place a bucket underneath the pump, and connect your Clayton Brake Washer to your shop's air supply. Fluid should immediately begin gushing out of the pump and into the bucket. If this is the case, then you'll need to replace the tools and hoses assembly.
- If no solution is pumping out of the pump, and you have confirmed that you have adequate air flow coming out of the regulator, then you will need to replace the pump.

- **NOTE:** A common sign of a blown pump is a steady stream of air coming from the blue nozzle.

Parts to order:

- 300-001B Pump
- 300-009B Regulator
- 500-A100 Tools and hoses assembly for drum style Brake Washers

Problem: Brake Washer is pumping solution at too high a rate.

- The regulator is putting out too much pressure. You will need to replace the regulator.
- **CAUTION!!** Do not attempt to adjust the regulator in the shop. Any attempt to adjust the regulator immediately voids the warranty on BOTH the pump and the regulator.

Parts to order:

- 300-009B Regulator

Problem: Oil Magnet has sunk beneath the surface of the solution.

- The oil magnet is saturated with oil. Wring out the oil into your shop's waste oil container. If the oil magnet still sinks, or oil remains in solution, replace oil magnet.

Parts to order:

- 300-006EA Clayton Oil Magnet for drum style Brake Washers
- 400-001 Clayton Oil Magnet for BCE-200 and BCE-400 series washers

Problem: Brake Washer has lost its cleaning strength.

- Drain fluid reservoir and refill with fresh solution.
- Solution should be changed after 450 brake jobs, or after 2 months, whichever comes first.

Parts to order:

- 300-361CS 6 liter case of Clayton TNT Brake Cleaning Concentrate
- 300-305 5-gallon pail of Clayton TNT Brake Cleaning Concentrate

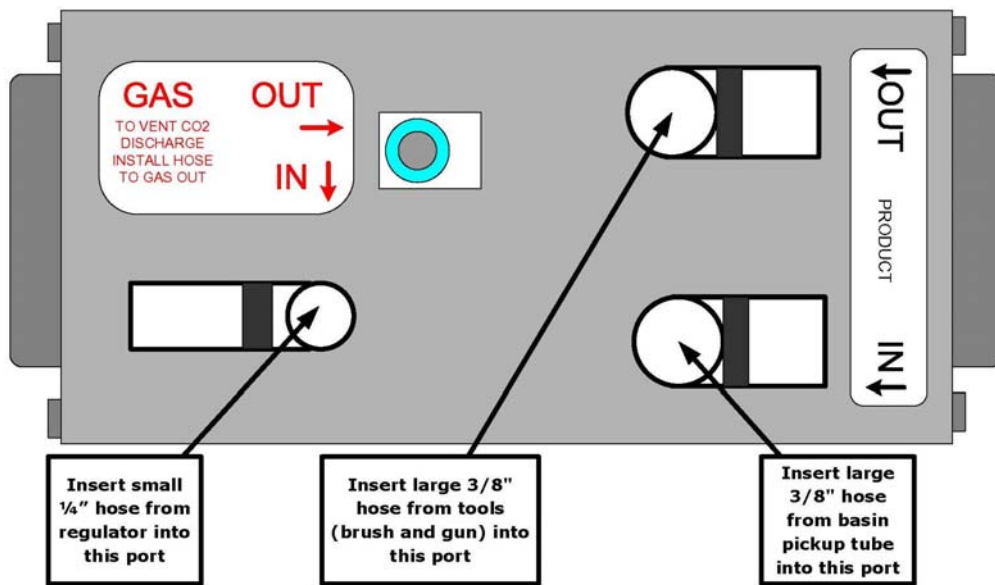

To connect a hose into a port, pull the small tab alongside the port AWAY from the hose. This will open the port. Gently push the hose into the port until it is all the way in. Slide the tab back towards the hose until you feel it lock into place. This will ensure a positive connection.

Figure 1. Brake Washer Pump Setup

For detailed parts breakdowns and troubleshooting, please visit:

www.BrakeWasher.com

**If you need technical support, please call Clayton Associates, Inc.
at 732-363-2100**

